

Volumen dedicado a conmemorar los
25 AÑOS DE ACCESO A LA CATEDRA
por el

PROF. DR. DON JULIAN SAN VALERO APARISI

UNIVERSIDAD DE VALENCIA

FACULTAD DE FILOSOFIA Y LETRAS
Departamento de Historia Medieval

LIGARZAS

5

VALENCIA
1973

tudios sobre núcleos de fábricas, rutas de comercialización, de distribución, zonas de industrialización, influencias políticas, vías de penetración, calidades de productos, protecciones aduaneras y aún crisis comerciales o de fabricación.

Mientras tanto, las filigranas ya publicadas podrán servir de instrumento de datación a muchos códices que los historiadores de la Literatura utilizan en sus estudios.

Don José Sánchez Real ha tenido la amabilidad y gentileza de ordenar por temas las filigranas que aparecen en este volumen. Los motivos que forman las filigranas suelen ser simples en la primera época: dentro de un mismo tema las ha ordenado por orden creciente de complejidad, si bien en determinados casos ha preferido una ordenación puramente cronológica. Si el motivo que forma el "tipo" presenta pequeños cambios, estos se consideran como variantes.

Al final de cada artículo se han añadido unos índices de motivos y cronológicos para que puedan conocerse la coetaneidad de las marcas y su posible relación.

Ubieto

FILIGRANAS DEL ARCHIVO MUNICIPAL DE CASTELLON DE LA PLANA ("MANUAL DE CONSELLS")

JUAN LOPEZ PLA
MARIA JOSEFA MARTIN CREGO

El Archivo Municipal de Castellón de la Plana contiene abundantes fondos, entre los que destaca de manera sobresaliente la serie de "Manual de Consells", fundamentales para conocer la vida de esa población.

Los historiadores locales ha utilizado profusamente como fuente la magnífica colección, y han dado a conocer sus frutos en el "Boletín de la Sociedad Castellonense de Cultura". Pero hasta la fecha no habían interesado en el aspecto puramente material como son las "marcas de agua".

Hemos repasado los "Manual de Consells" comprendidos entre los años 1378 y 1493, ambos inclusive. Tales libros comienzan a redactarse el día 24 de junio de cada año (día de san Juan Bautista) y alcanzan hasta el 23 de junio del año siguiente. En cada una de las figuras que repetimos hemos tomado nota de los siguientes extremos:

Marca de agua.

Corondeles.

Puntizones.

Estos últimos se hallan siempre en cada lámina, suponiendo que en toda la página es igual.

Al pie de cada filigrana se encuentra la notación de los años en que aparece cada dibujo, así como la frecuencia con que se repite, que va entre paréntesis. Si corresponden a varios años, se dan siempre los totales.

Hemos limitado nuestro estudio sólo a la serie de "Manual de Consells", ya que las restantes serán objeto de otros estudios.

Antes de terminar queremos hacer constar nuestro agradecimiento a Don José Sánchez Adell, por su colaboración y ayuda en el Archivo; y a Don José Sánchez Real, por haber ordenado por temas —como aquí aparecen publicados— los calcos que obtuvimos.

AGNUS DEI



1. 1455 - 1456 (11)



2. 1455 - 1456 (1)

AGUILA

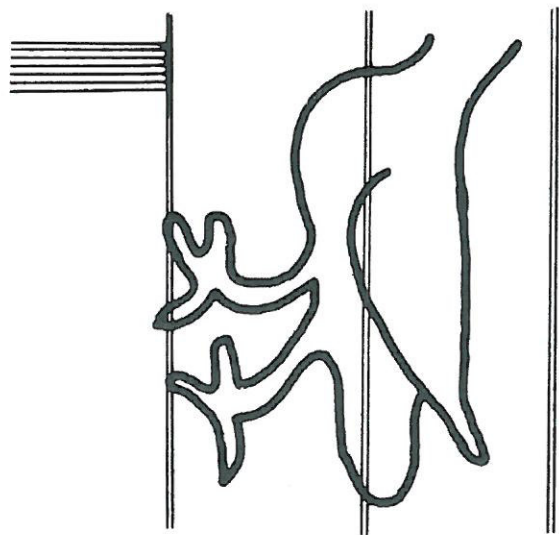

3. Se encuentra como nota en ms. de 1400 (1).

ANCLA

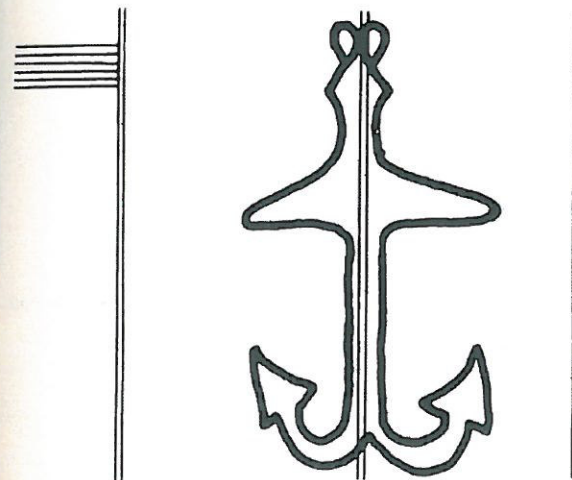

4. 1417-1418 (10); 1423-1424 (1); 1427-1428 (13); 1435-1436 (6); 1439-1440 (22); 1443-1444 (18); 1444-1445 (3); 1445-1446 (7); 1448-1449 (16) y 1449-1450 (10). Total: 106.

ANILLO

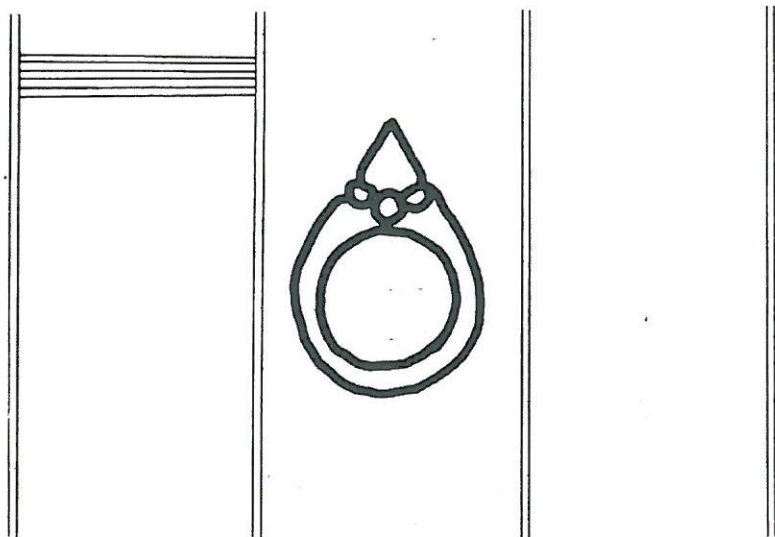

5. 1456-1457(41); 1457-1458 (19); 1460-1461 (21) y 1468-1469 (19). Total: 100.

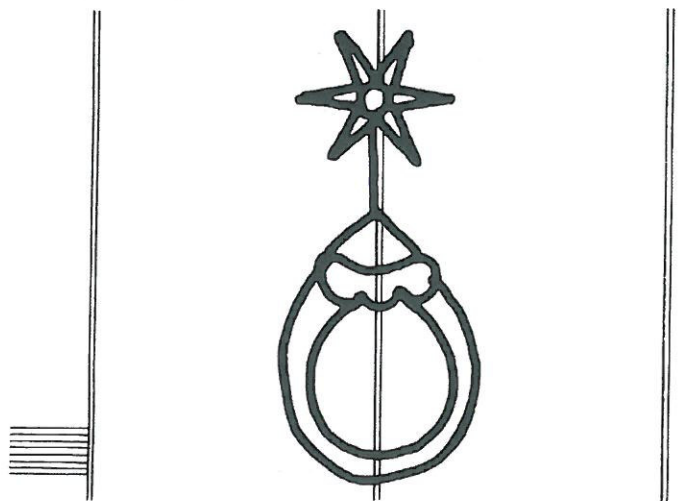

6. 1479-1480 (2).

ARCO

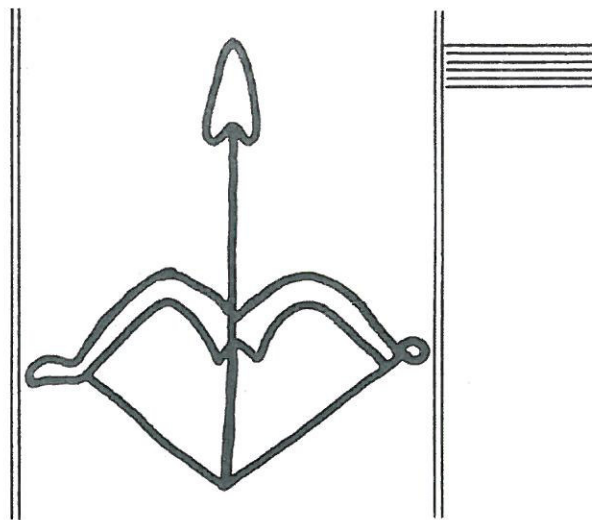

7. Se encuentra en ms. de 1400 (2).

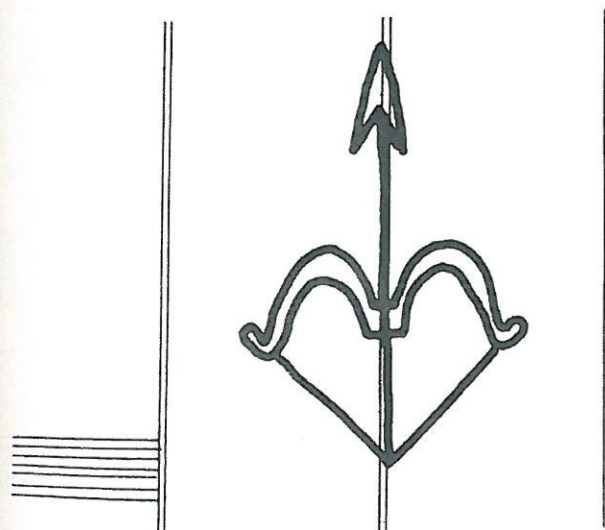

8. 1430-1431 (19).

BALANZA

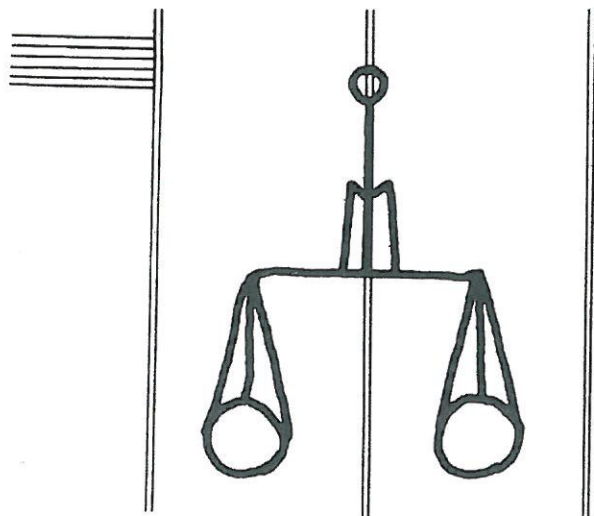

9. 1435-1436 (22).

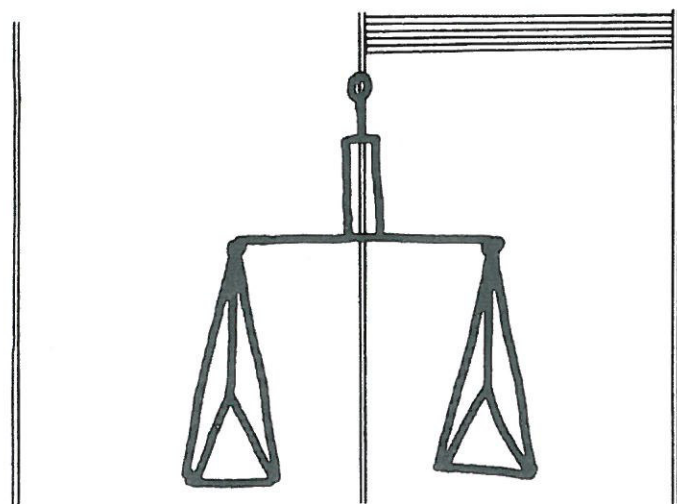

10. 1450-1451 (14) y 1459-1460 (1). Total: 15.

BALANZA

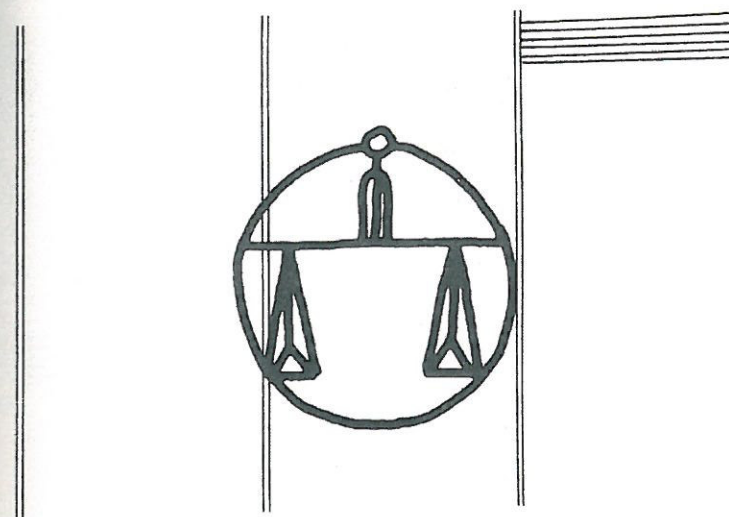

11. 1454-1455 (33) y 1455-1456 (13). Total: 46.

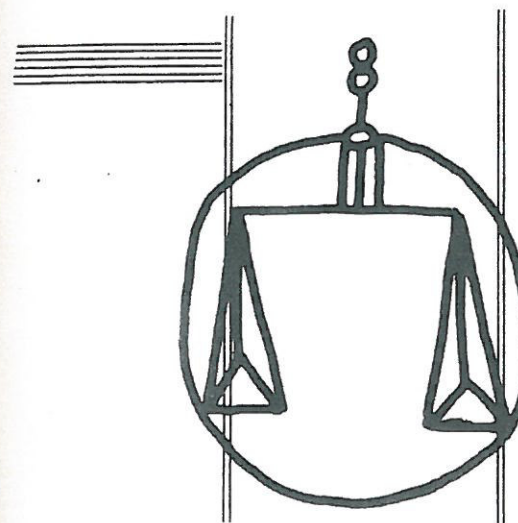

12. 1457-1458 (16).

BASILISCO

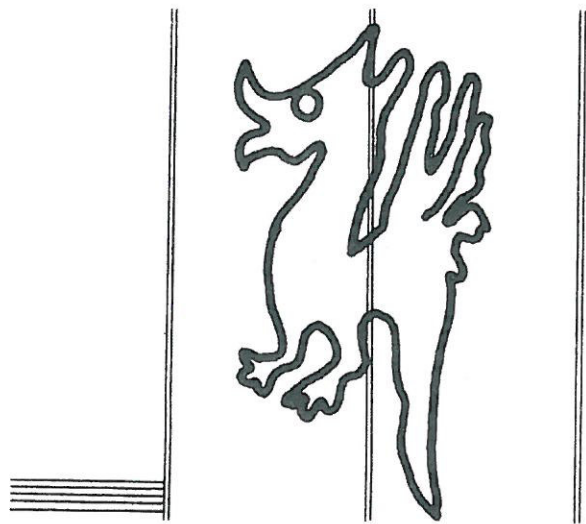

13. 1417-1418 (17).

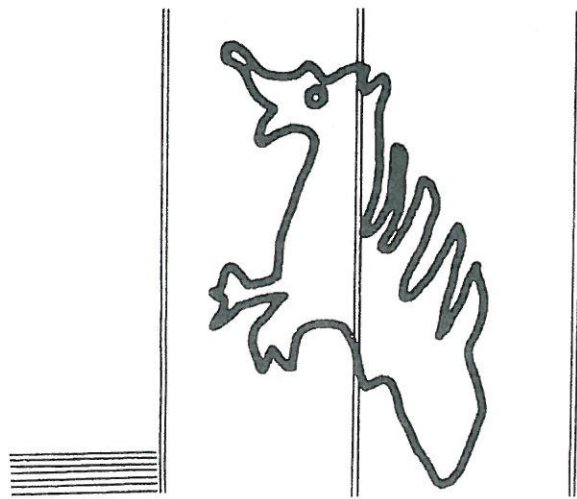

14. 1463-1464 (2).

BASILISCO

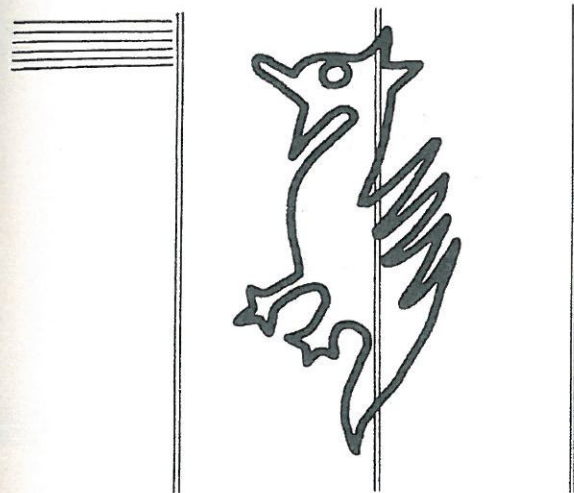

15. 1464-1465 (5).

BONETE

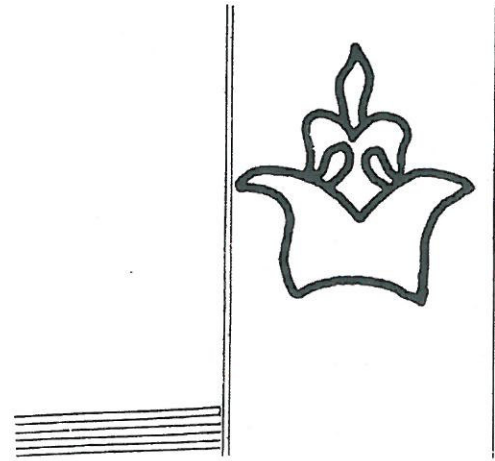

16. 1427-1428 (1).

BONETE

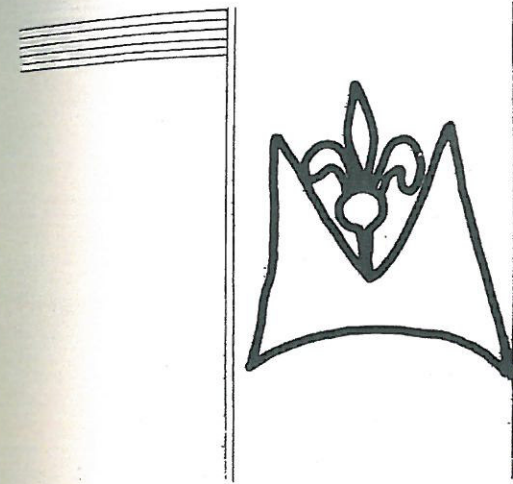

17. 1458-1459 (5).

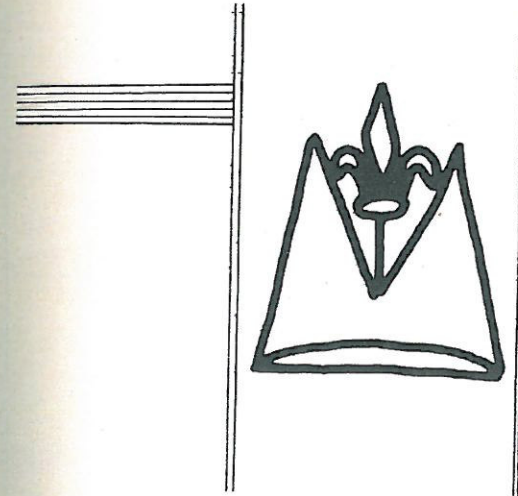

18. 1462-1463 (4).

BUEY

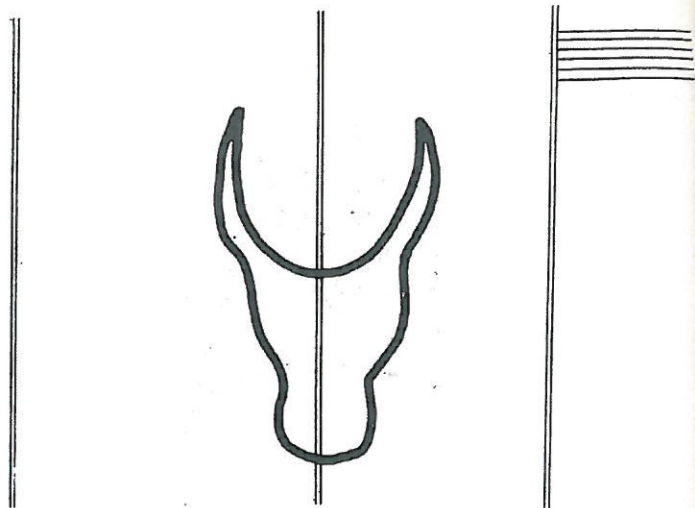

19. 1469-1470 (1).

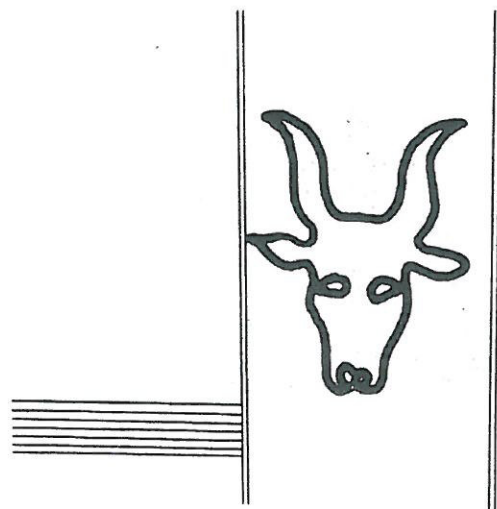

20. 1464-1465 (3) y 1468-1469 (1). Total: 4.

BUEY

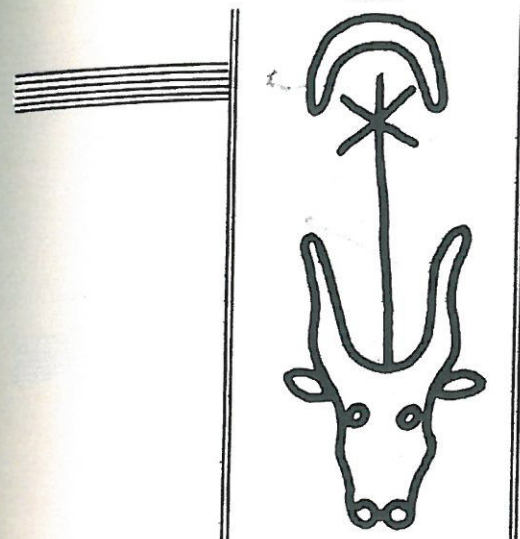

21. 1450-1451 (7) y 1463-1464 (1). Total: 8.

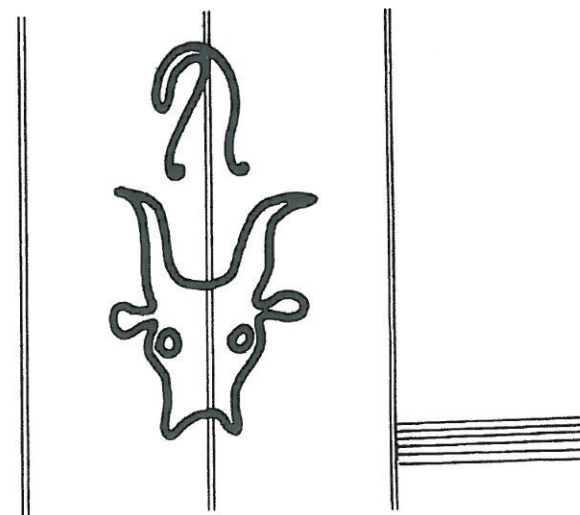

22. 1473-1474 (45).

BUEY

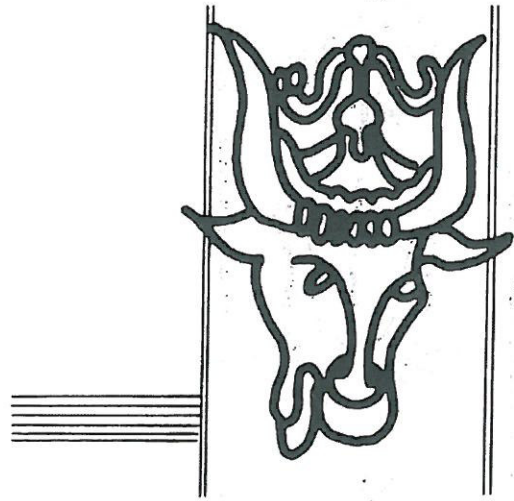

23. 1458-1459 (3) y 1459-1460 (1). Total: 4.

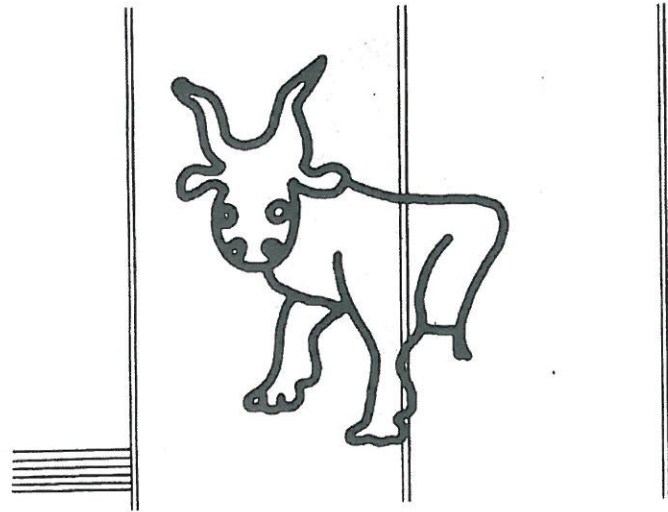

24. 1469-1470 (2).

CABALLO

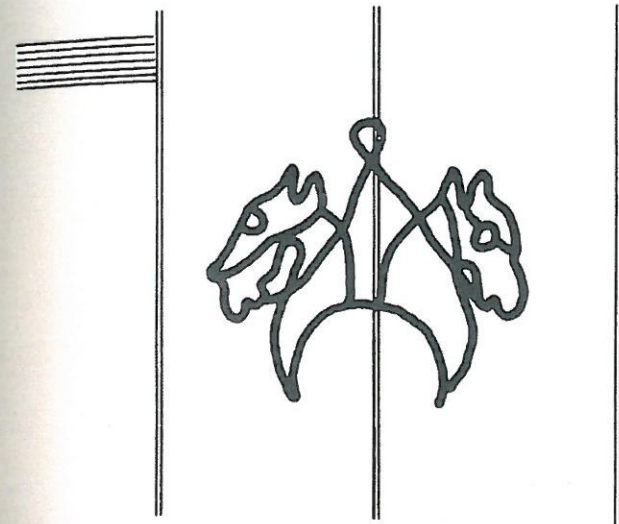

25. 1431-1432 (9).

CABEZA HUMANA

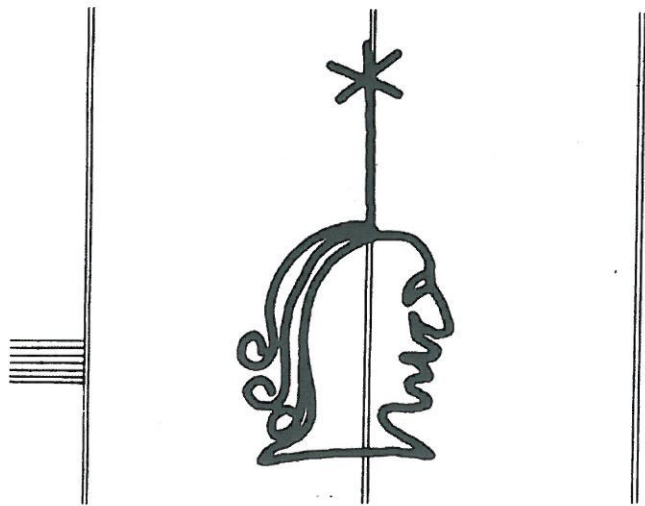

26. 1488-1489 (6).

CAMPANA

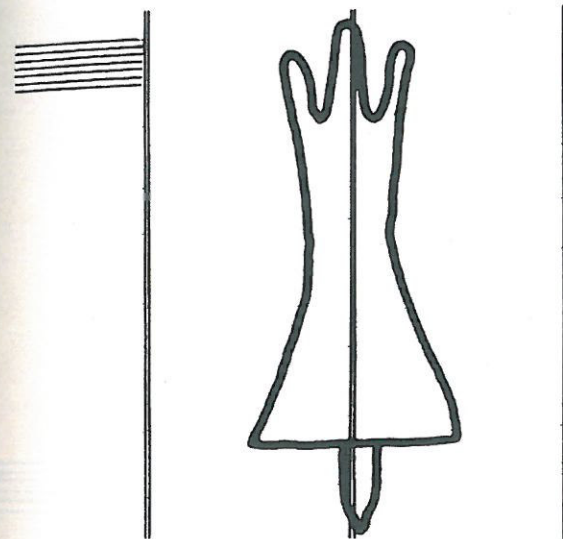

27. 1413-1414 (33); 1414-1415 (61); 1427-1428 (1); 1443-1444 (7)
y 1444-1445 (1). Total: 103.

CANTIMPLORA

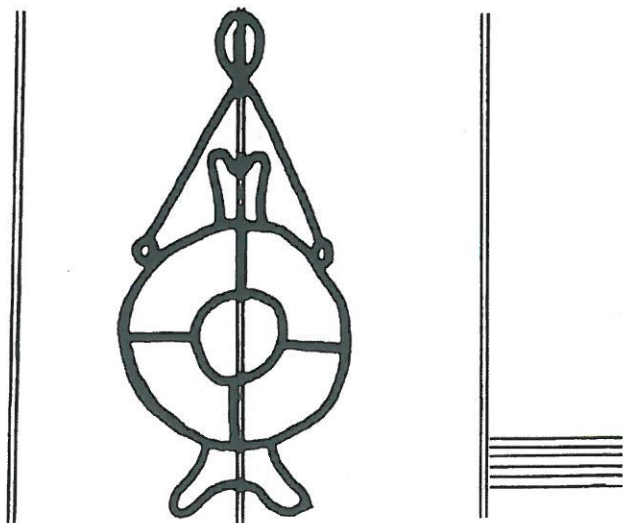

28. 1417-1418 (11).

CARRO

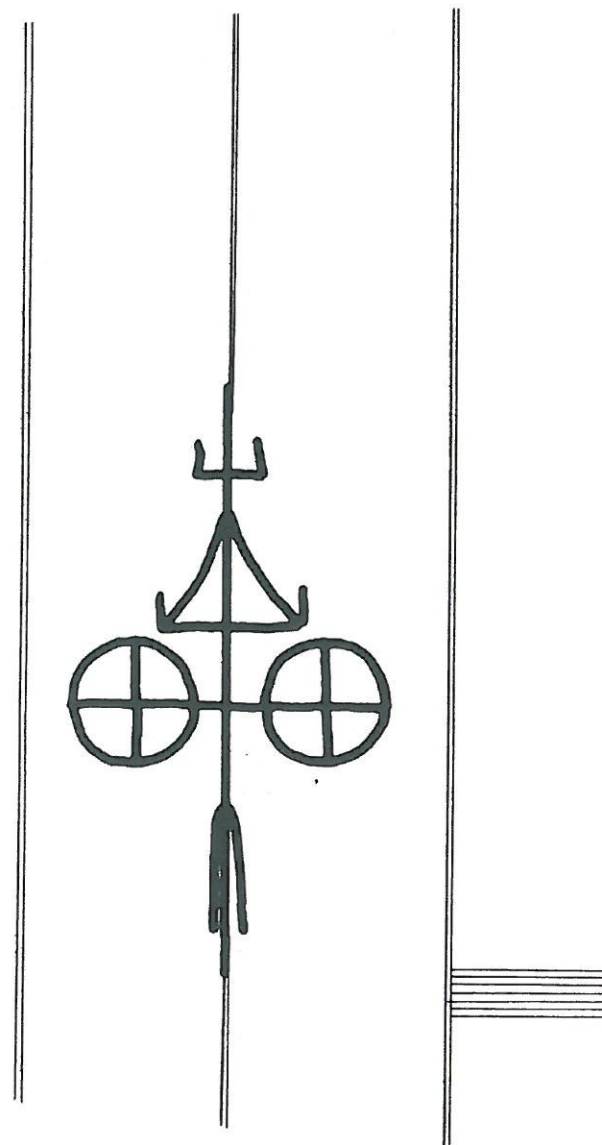

29. 1444-1445 (15) y 1445-1446 (14). Total: 29.

CARRO

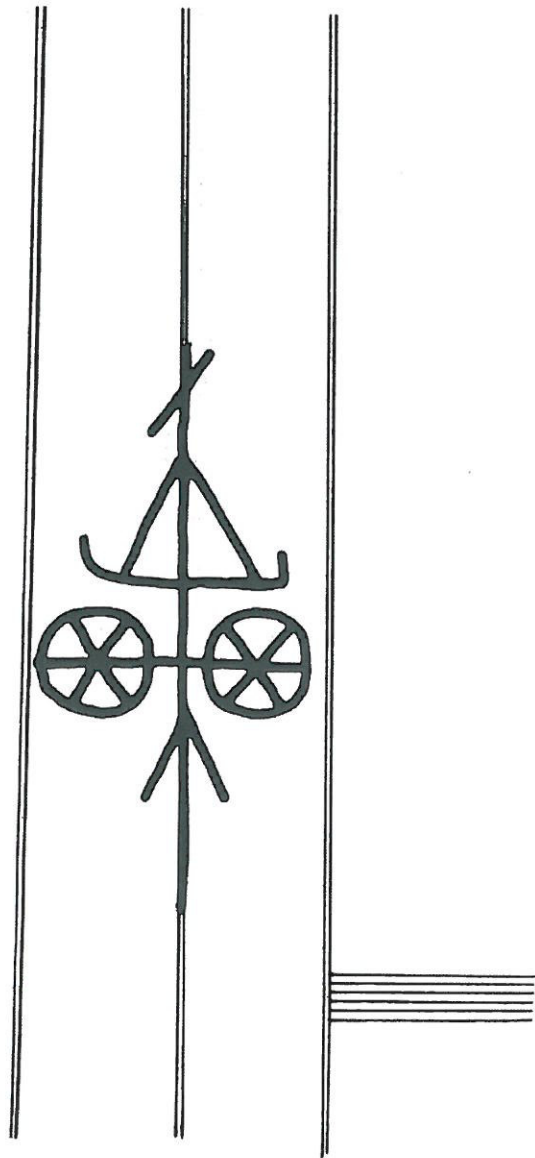

30. 1469-1470 (2).

CARRO

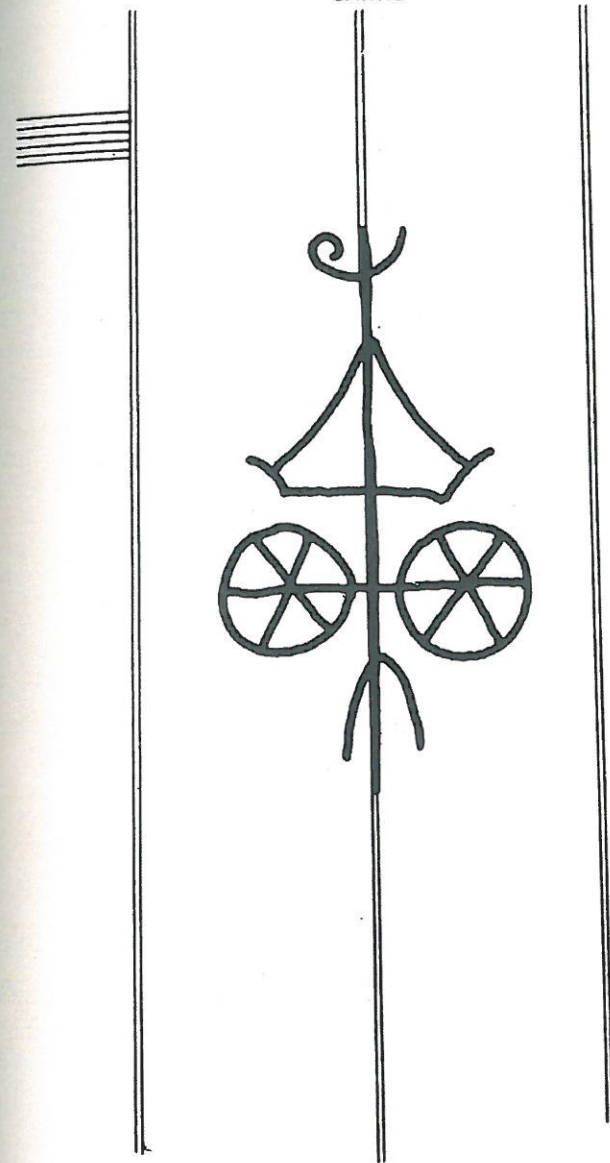

31. 1414-1415 (1); 1420-1421 (4); 1423-1424 (43) y 1427-1428 (5). Total: 53.

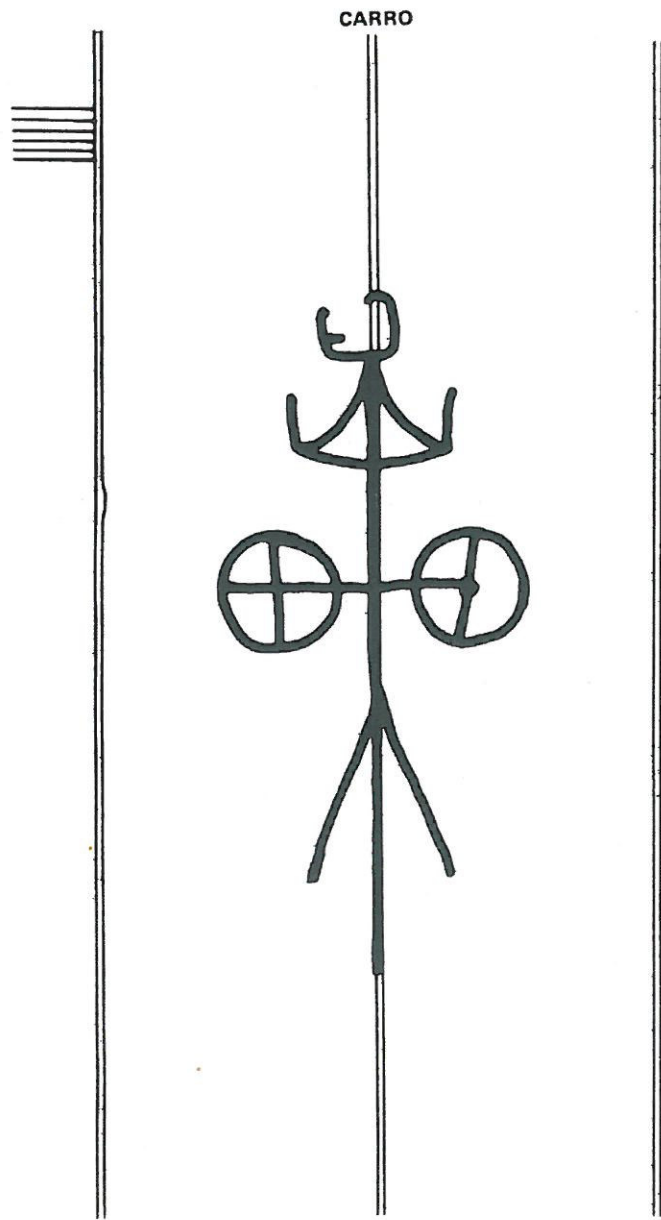

32. 1470-1471 (21).

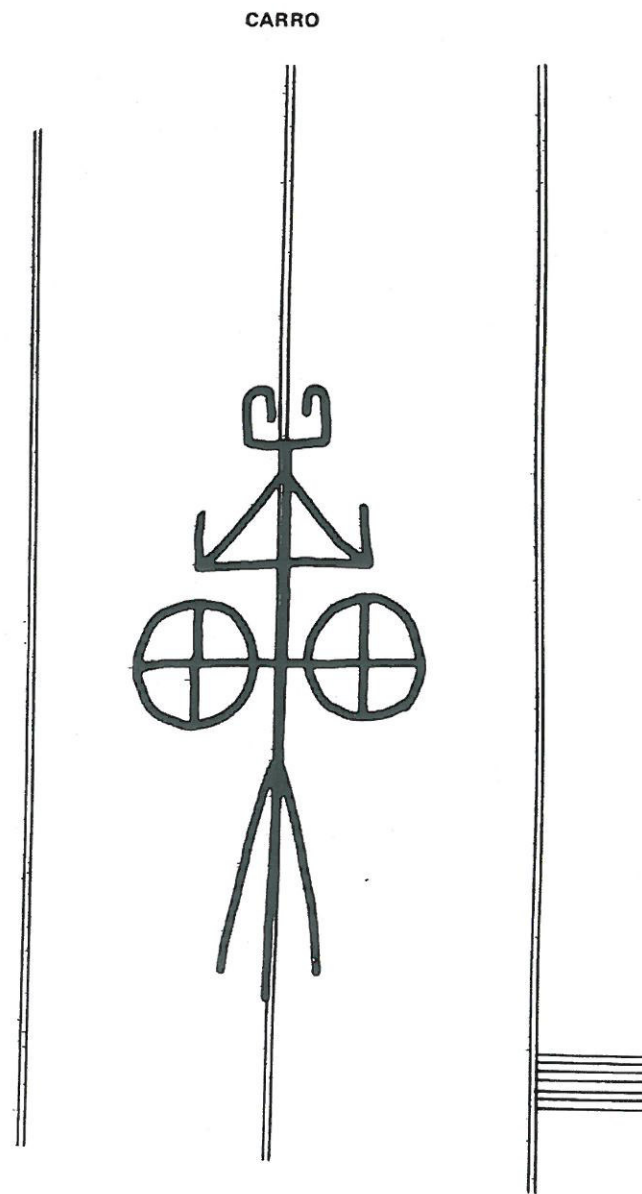

33. 1459-1460 (3) y 1462-1463 (4). Total: 7.

CARRO

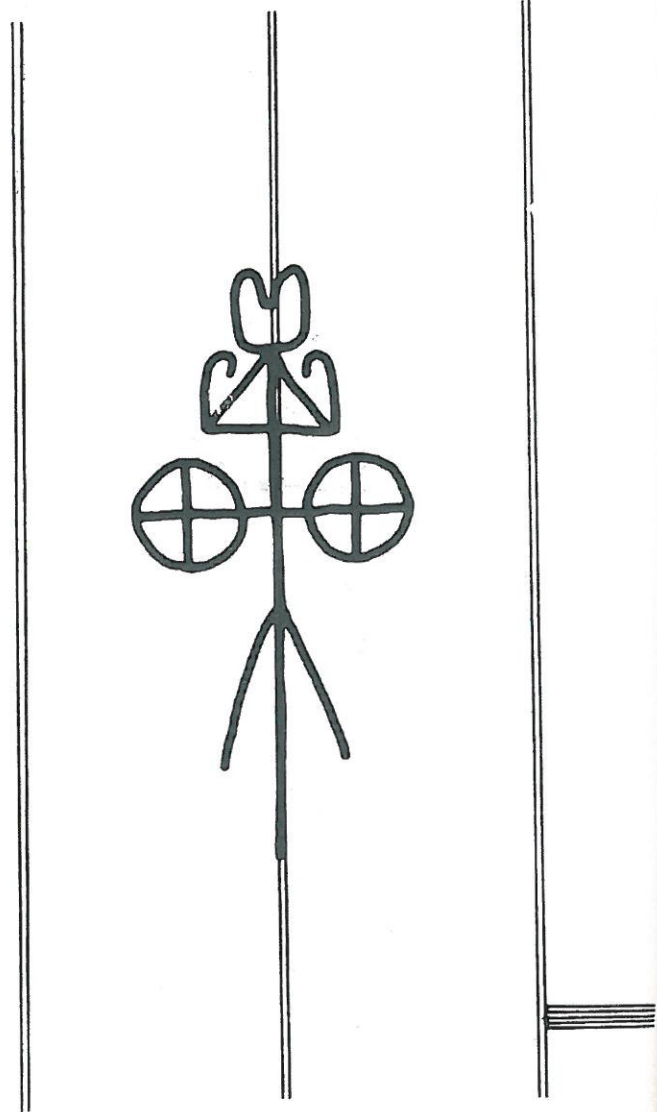

34. 1458-1459 (6) y 1459-1460 (45). Total: 51.

CARRO

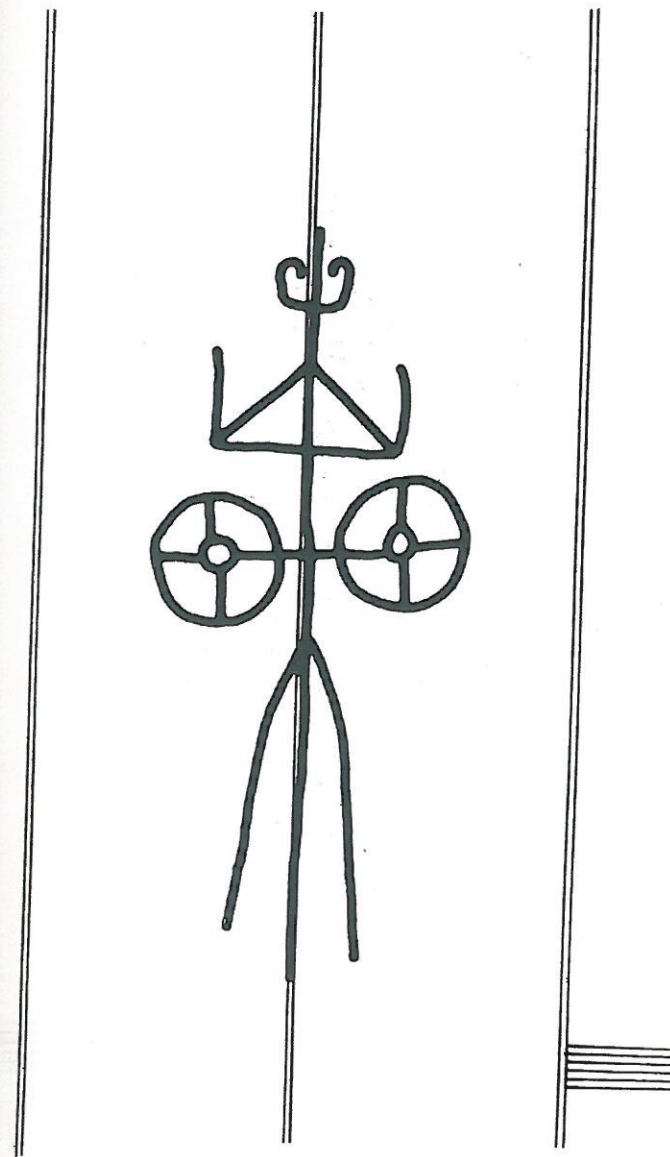

35. 1469-1470 (4).

CARRO

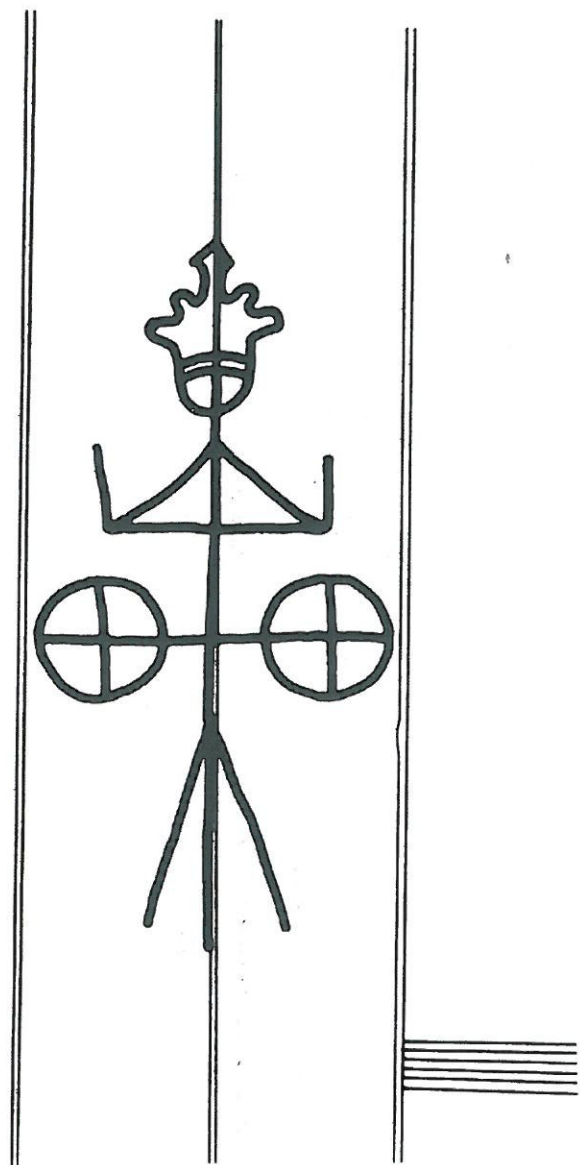

• 36. 1468-1469 (4).

CASTILLO

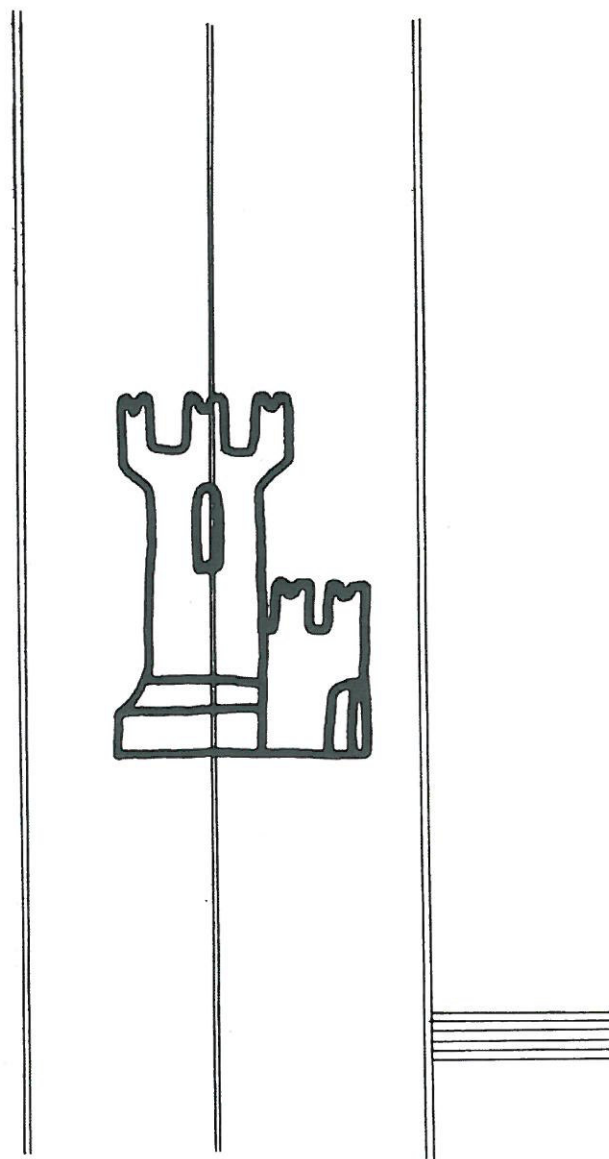

37. 1462-1463 (10) y 1463-1464 (1). Total: 11.

CIRCULO

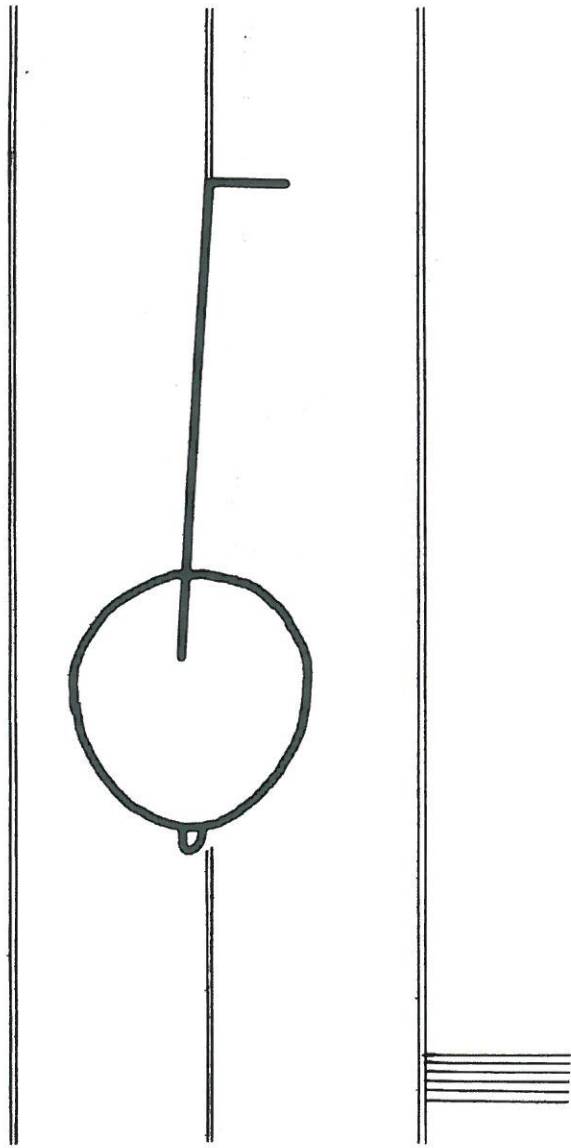

38. 1416-1417 (11).

CIRCULO

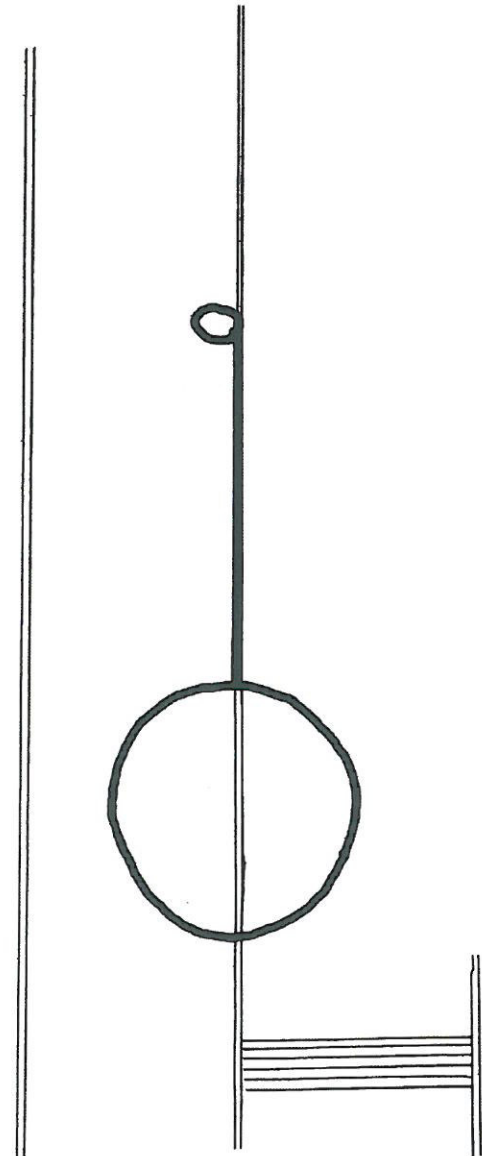

39. 1416-1417 (10).

CIERVO

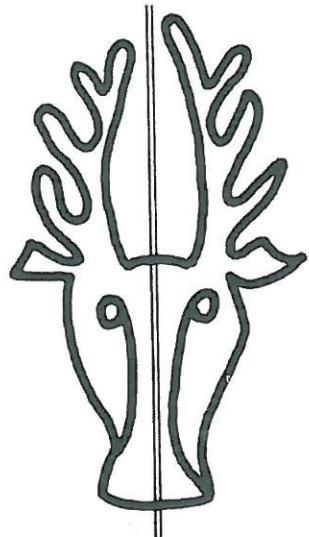

40. 1419-1420 (8).

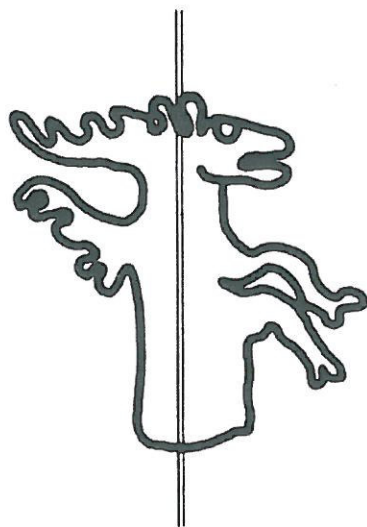

41. 1431-1432 (8).

COLUMNA

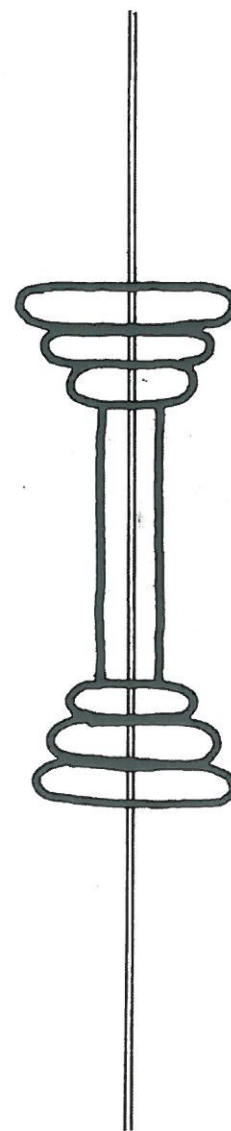

42. 1424-1425 (27).

CORONA

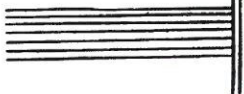
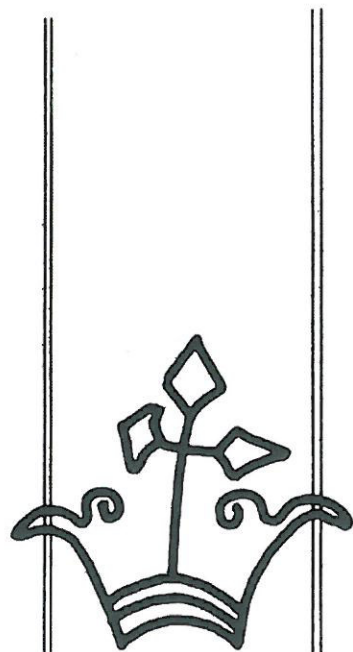

43. 1469-1470 (5).

CRUZ

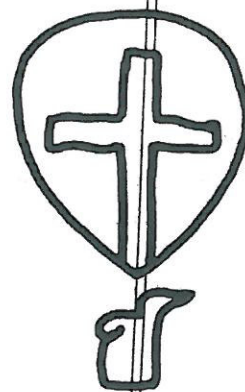

44. 1439-1440 (1)

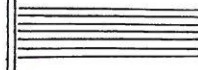

45. 1462-1463 (5).

CUERNO

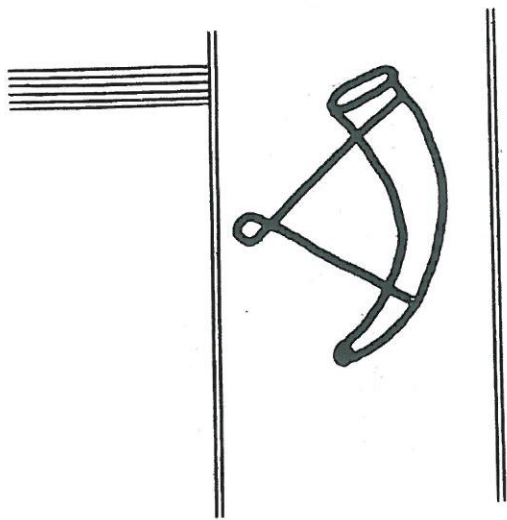

46. 1447-1448 (34).

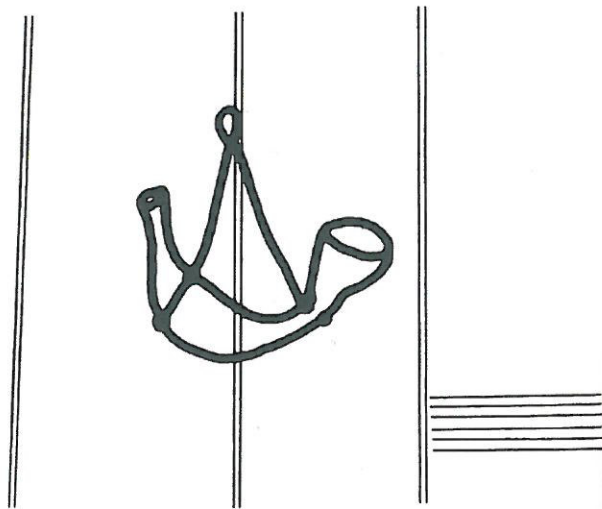

47. 1462-1463 (1).

CUERNO

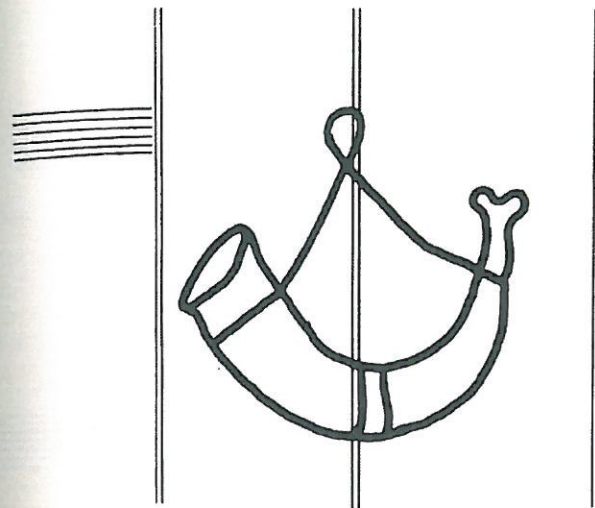

48. 1421-1422 (26) y 1449-1450 (3). Total: 29.

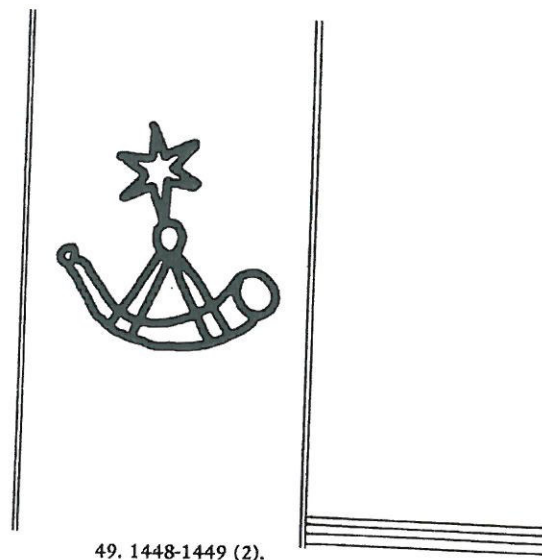

49. 1448-1449 (2).

DRAGON

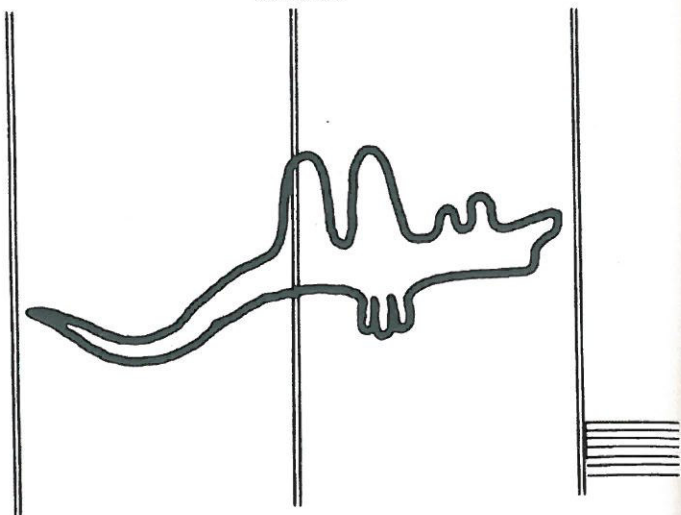

50. 1454-1455 (1).

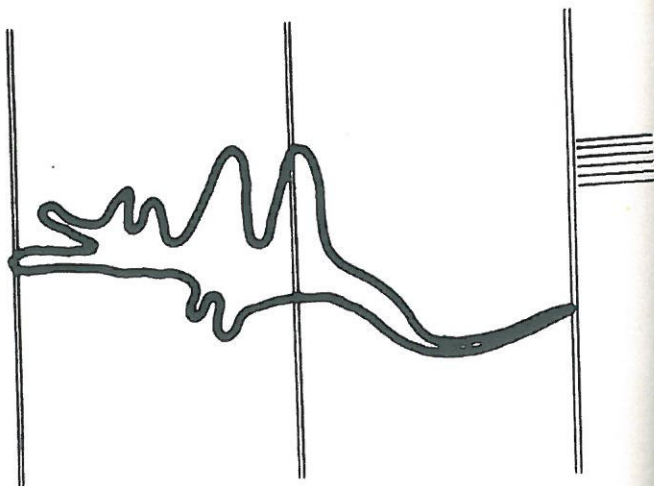

51. 1462-1463 (4).

ESCUDO

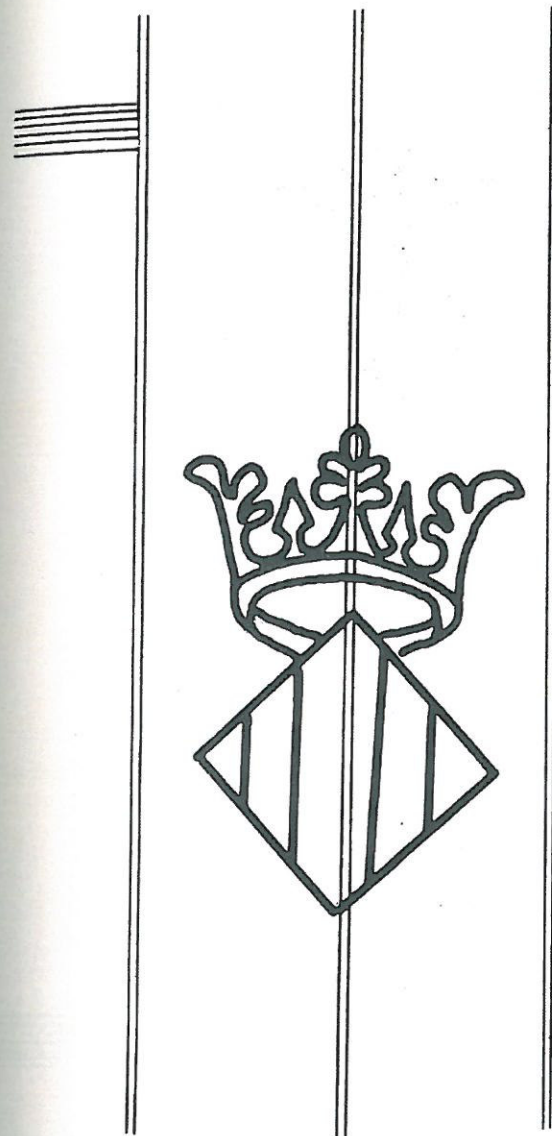

52. 1416-1417 (1); 1429-1430 (10) y 1431-1432 (22). Total: 33.

ESCUDO

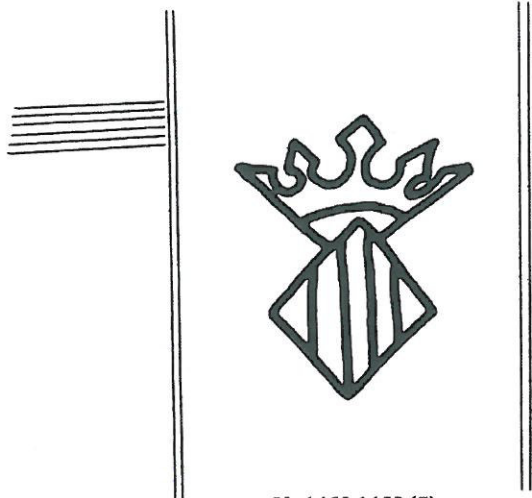

53. 1452-1453 (7).

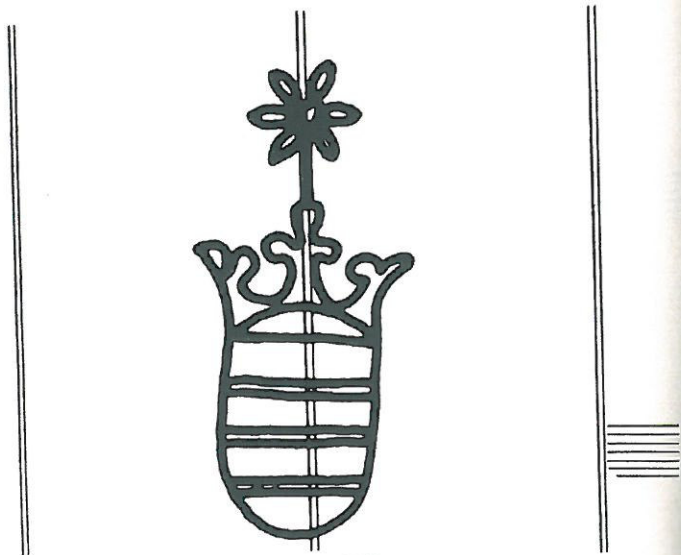

54. 1478-1479 (28).

ESPADA

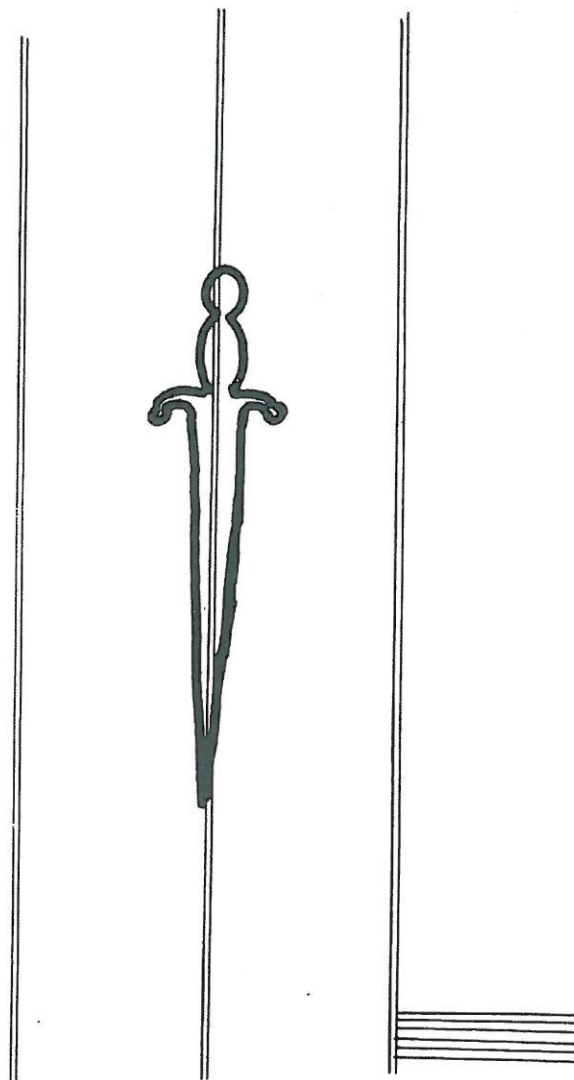

55. 1451-1452 (41).

ESPADA

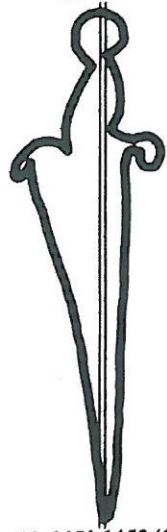

56. 1451-1452 (1).

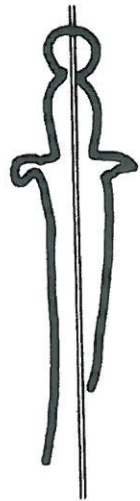
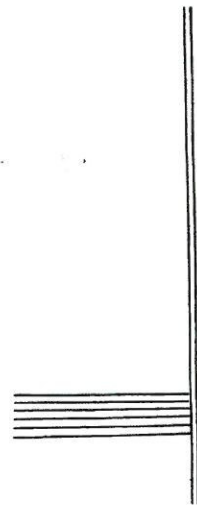
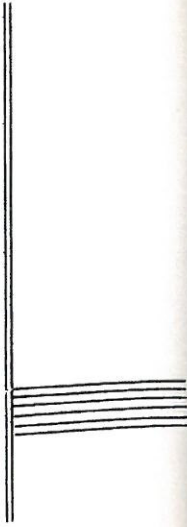

57. 1451-1452 (4).

ESTRELLA



58. 1436-1437 (1).

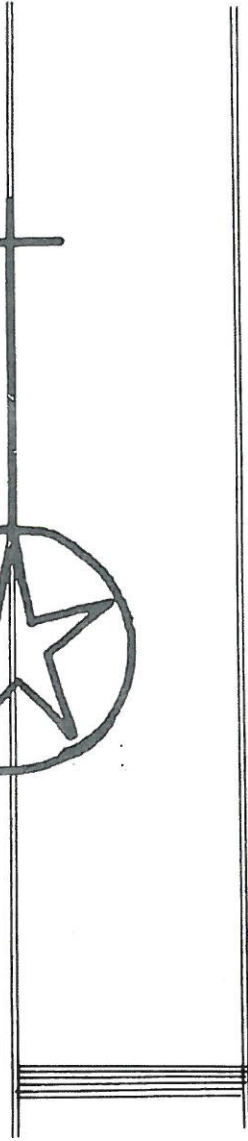

FLECHAS

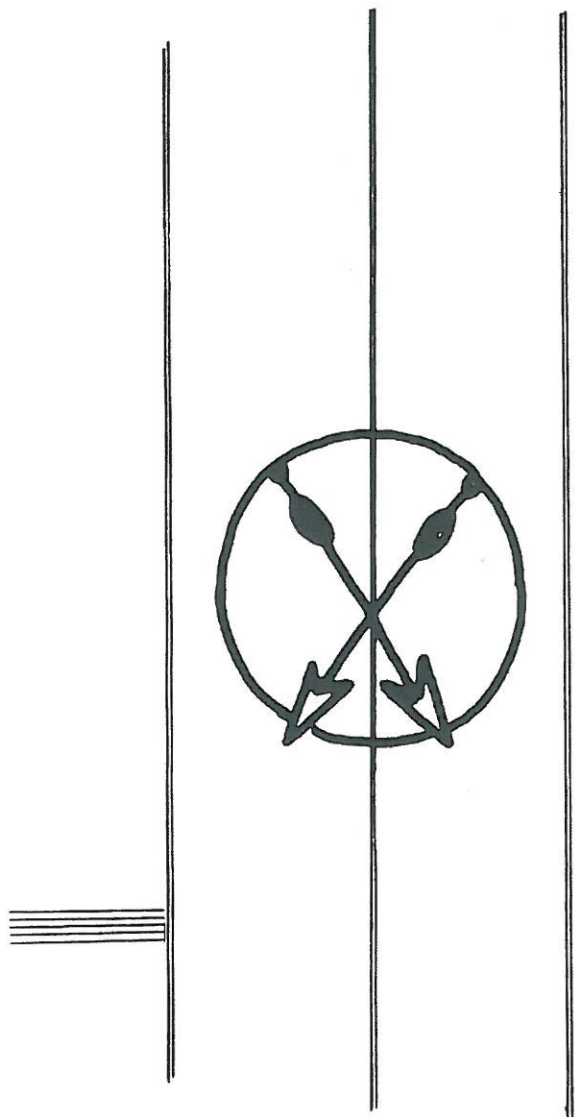

59. 1463-1464 (39); 1464-1465 (5) y 1468-1469 (2). Total: 46.

FLOR

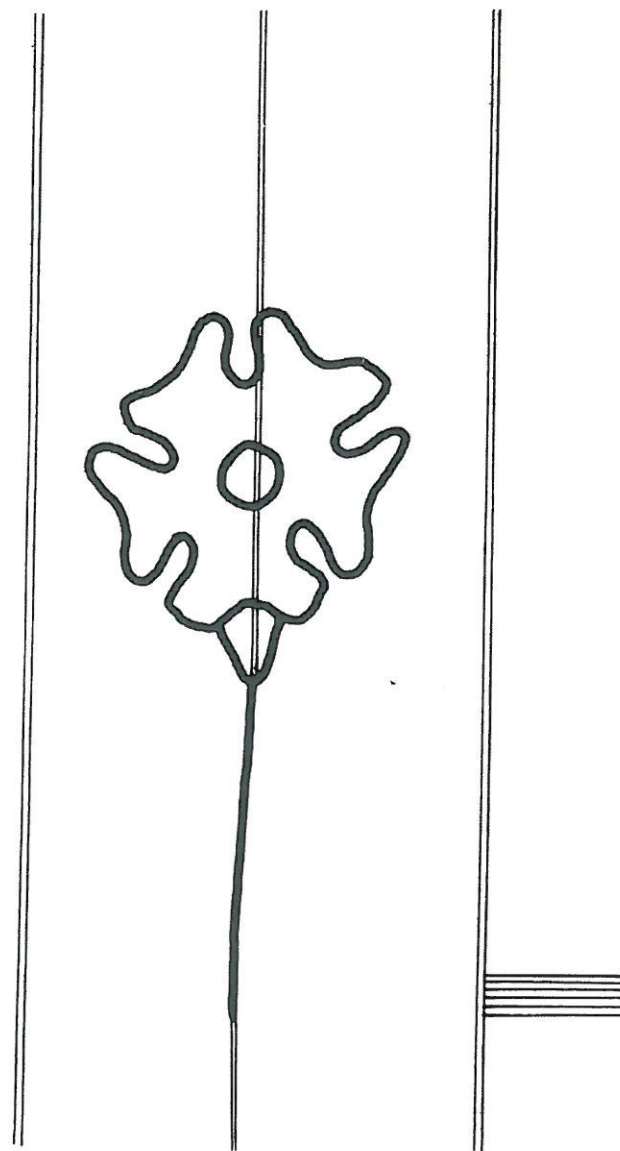

60. 1421-1422 (1) y 1422-1423 (1). Total: 2.

FLOR

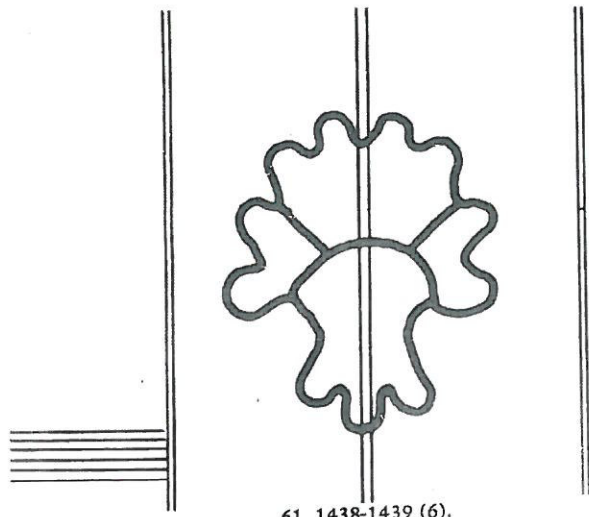

61. 1438-1439 (6).

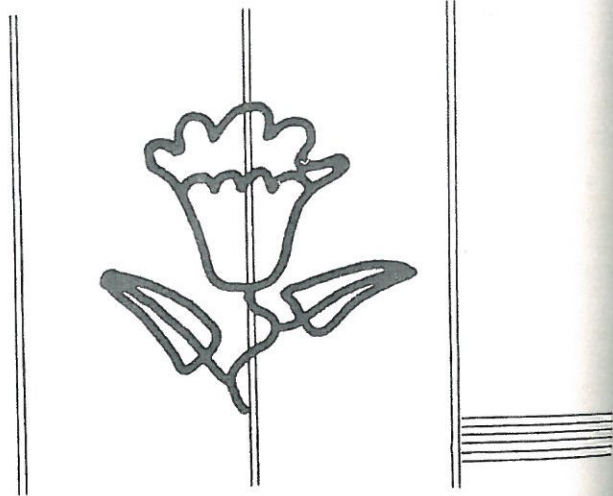

62. 1473-1474 (1).

FLOR

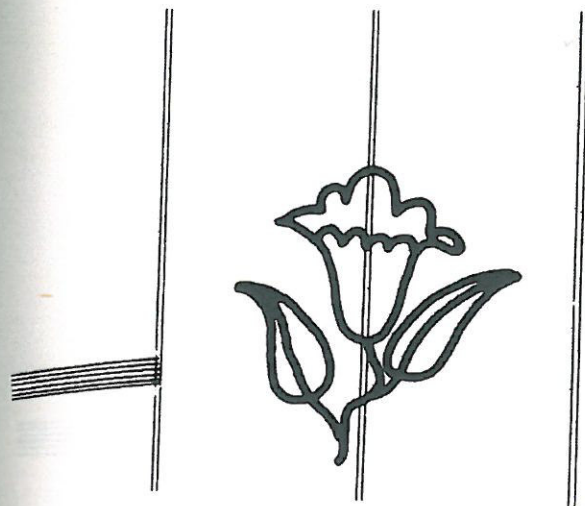

63. 1489-1490 (3).

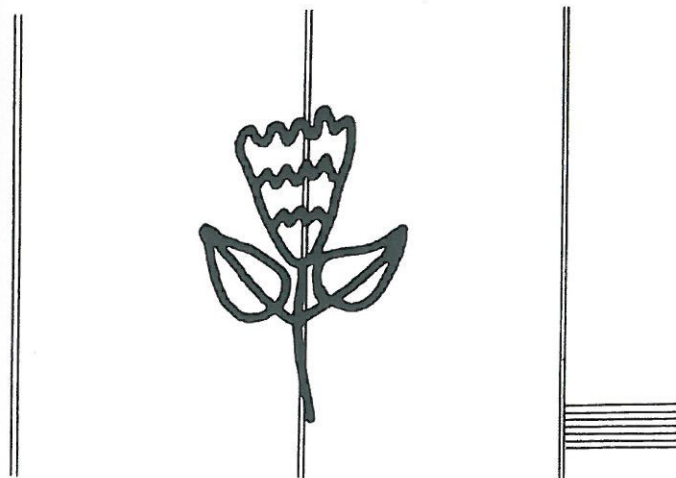

64. 1459-1460 (1).

FLOR

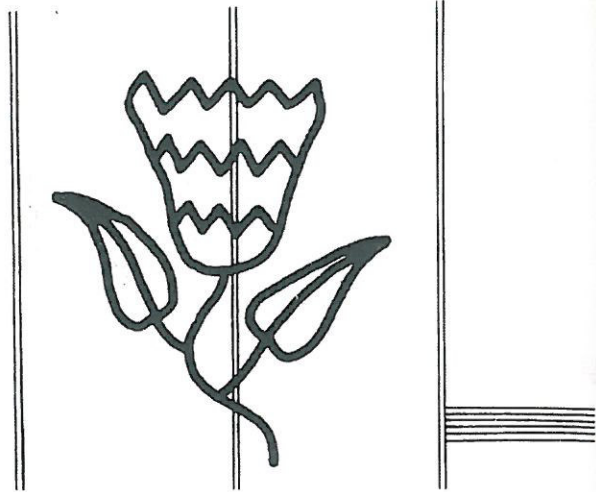

65. 1463-1464 (2).

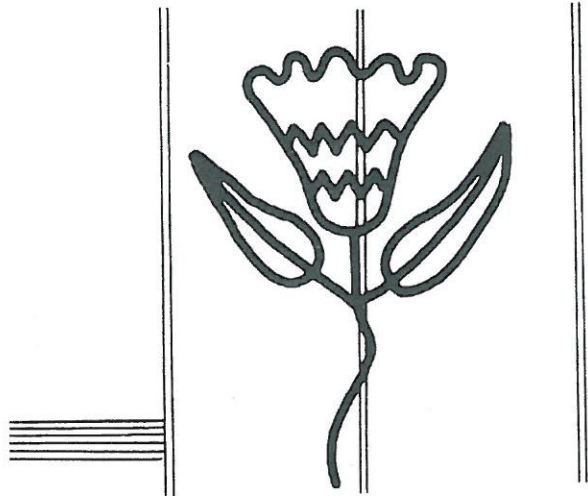

66. 1463-1464 (13).

FLOR

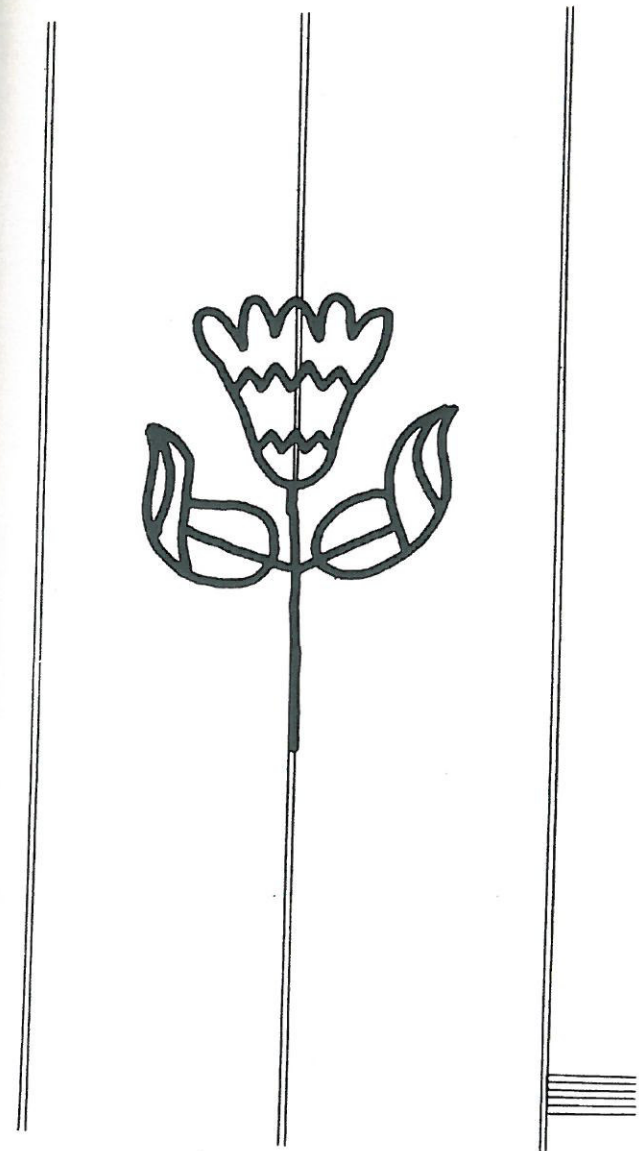

67. 1470-1471 (24).

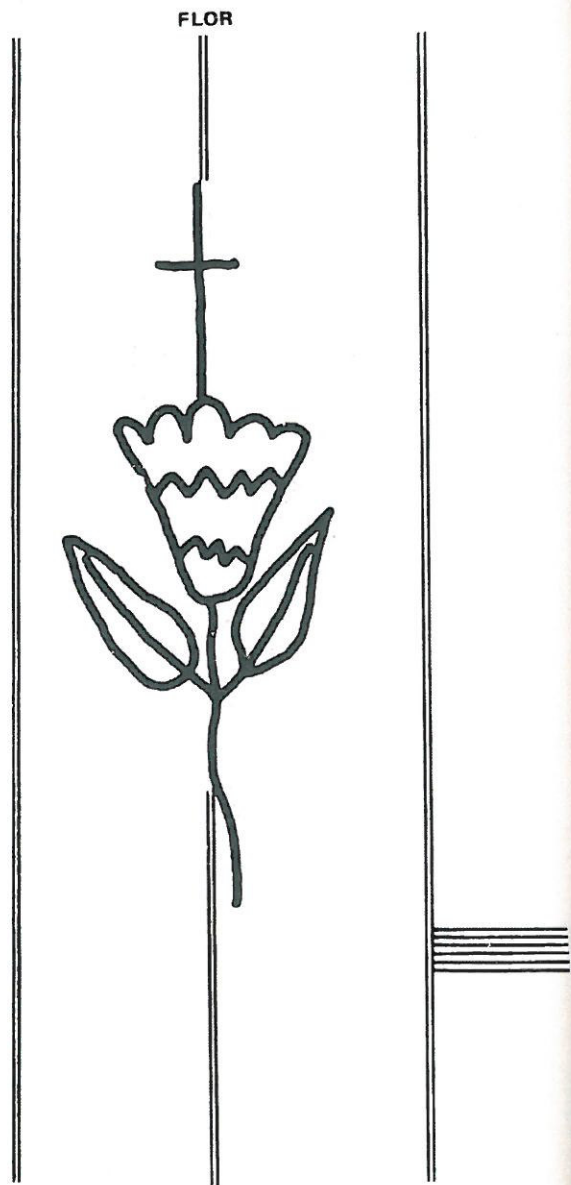

68. 1452-1453 (7).

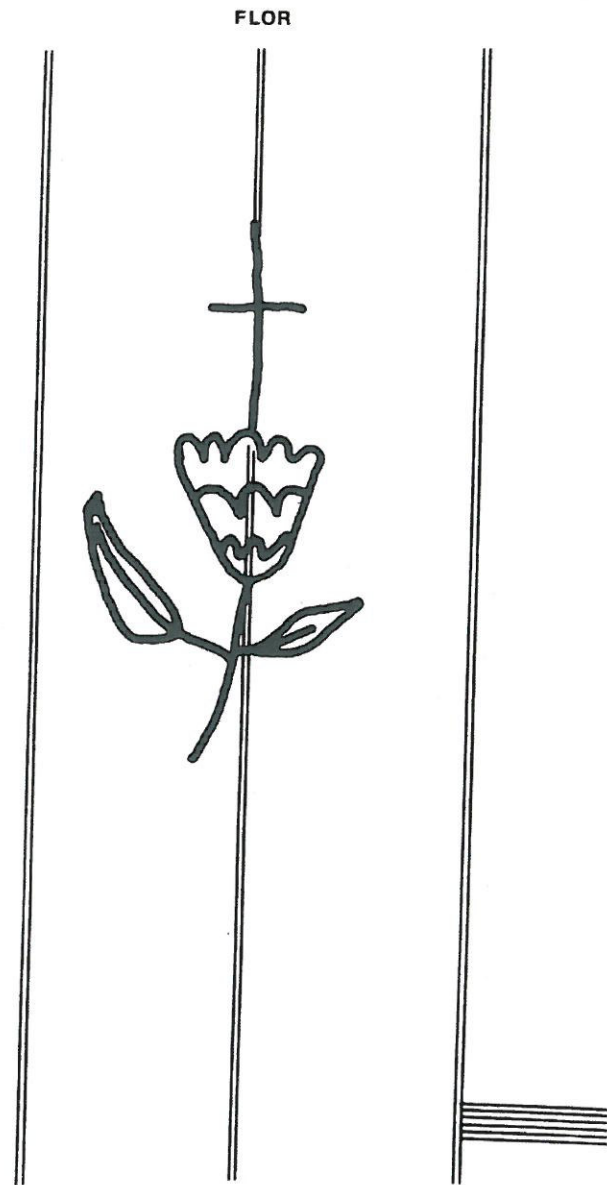

69. 1452-1453 (1).

FLOR

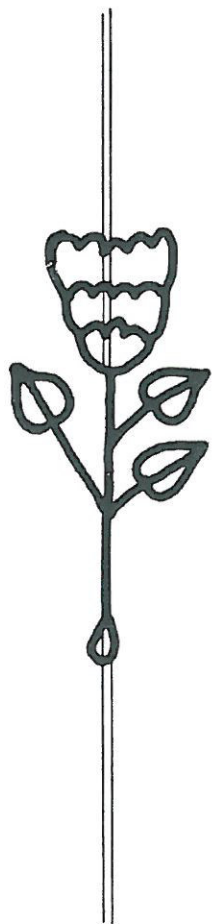

70. 1460-1461 (31).

FLOR

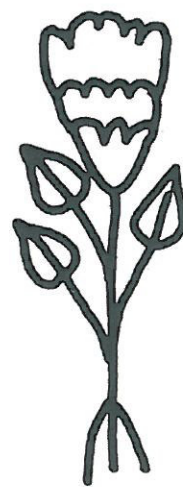

71. 1460-1461 (14).

INFLORESCENCIA

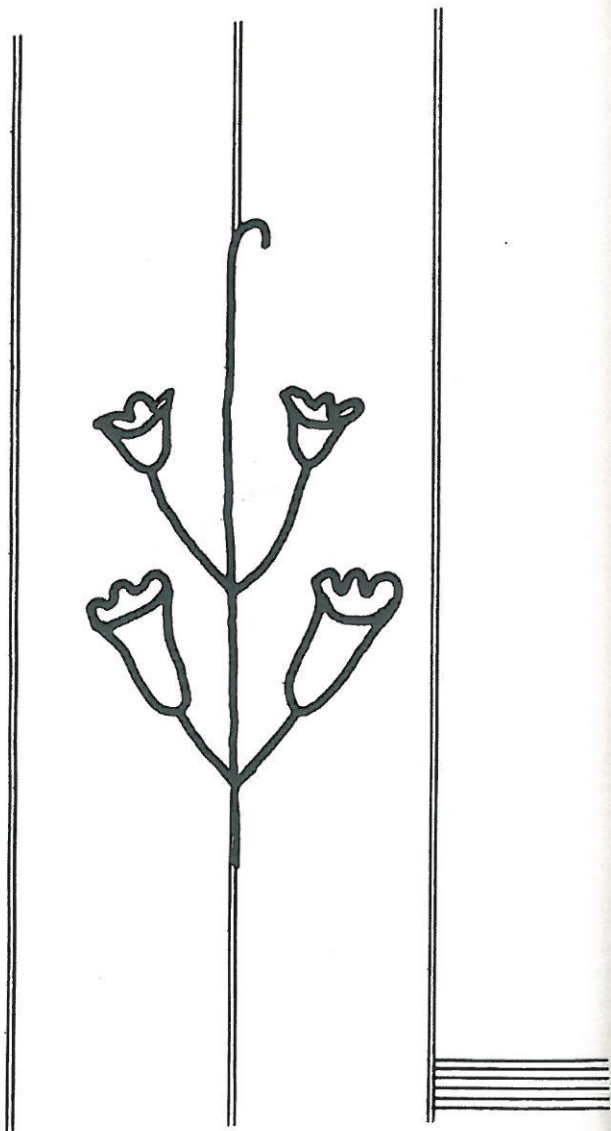

72. 1452-1453 (24).

LETRAS

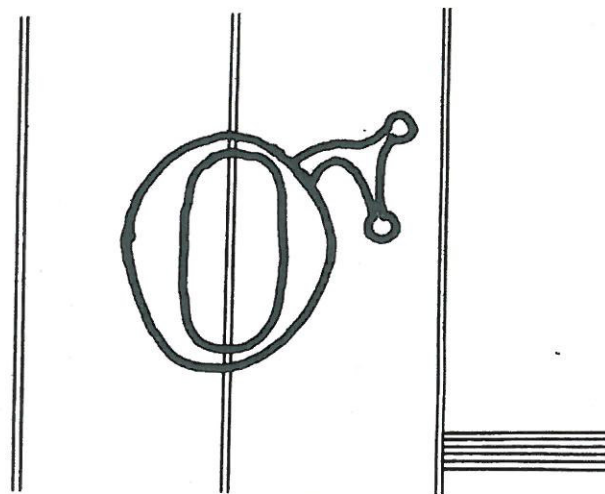

73. 1420-1421 (17).

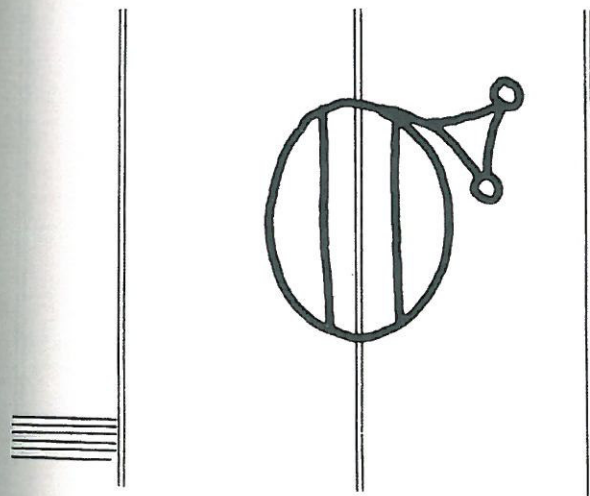

74. 1423-1424 (1).

LETRAS

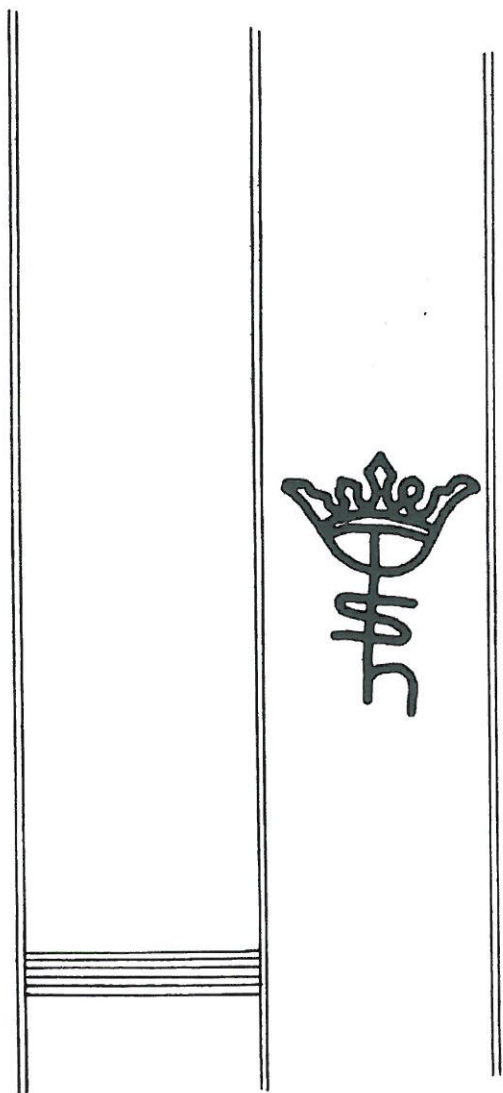

75. 1464-1465 (23).

LUNA

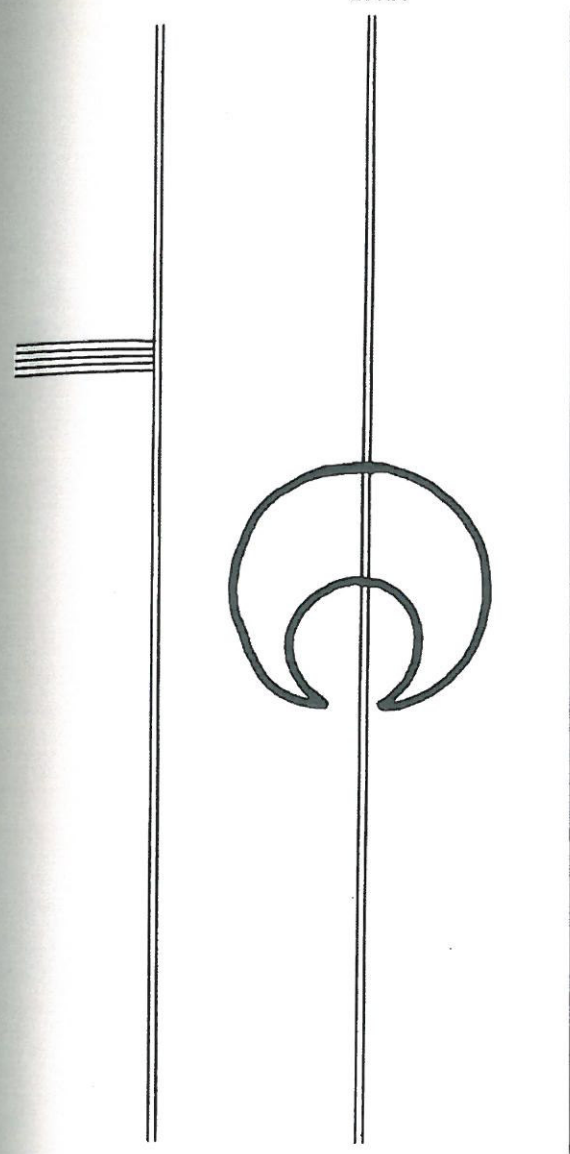

76. 1437-1438 (1) y 1438-1439 (9). Total: 10.

LLAVES

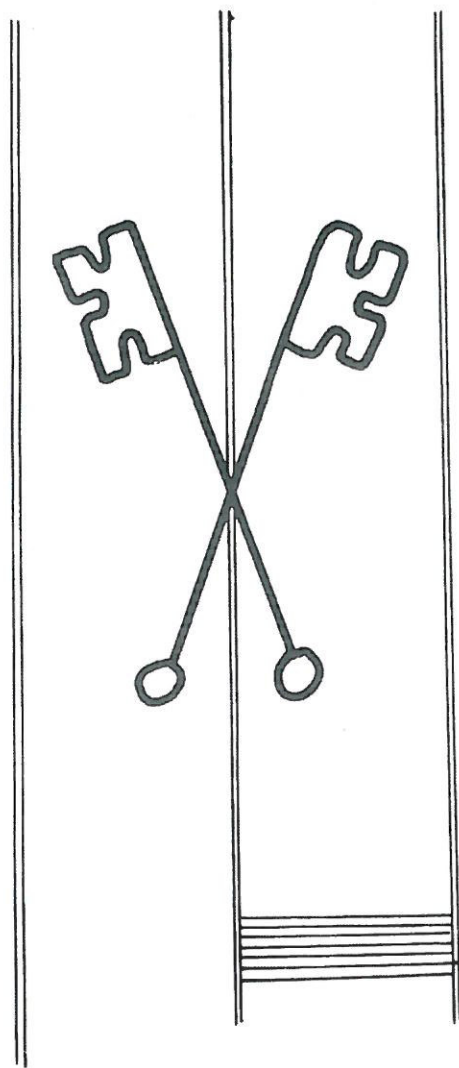

77. 1405-1406 (29).

MANO

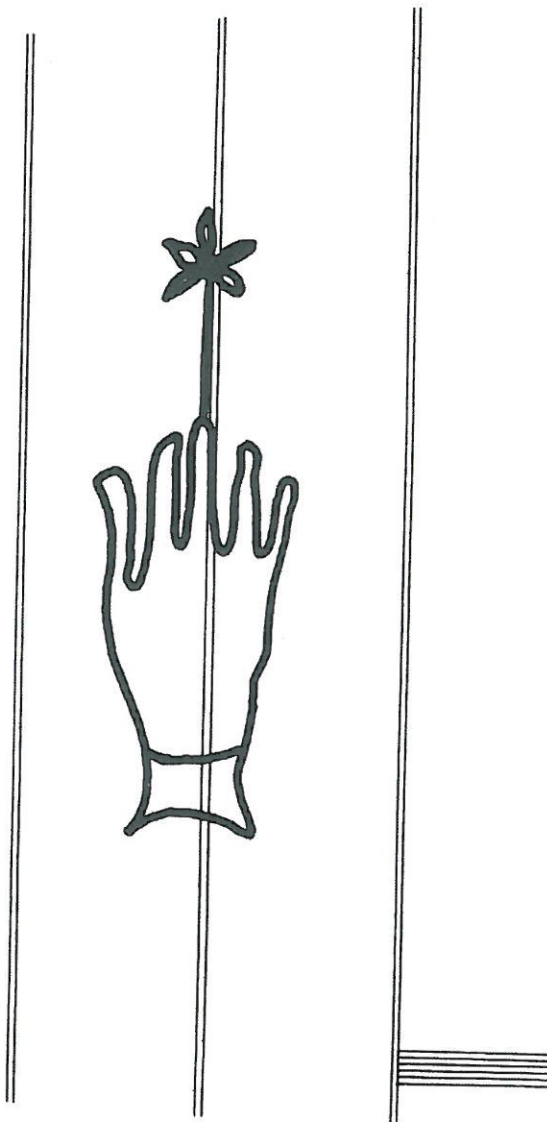

78. 1475-1476 (4) y 1477-1478 (29). Total: 33.

MANO

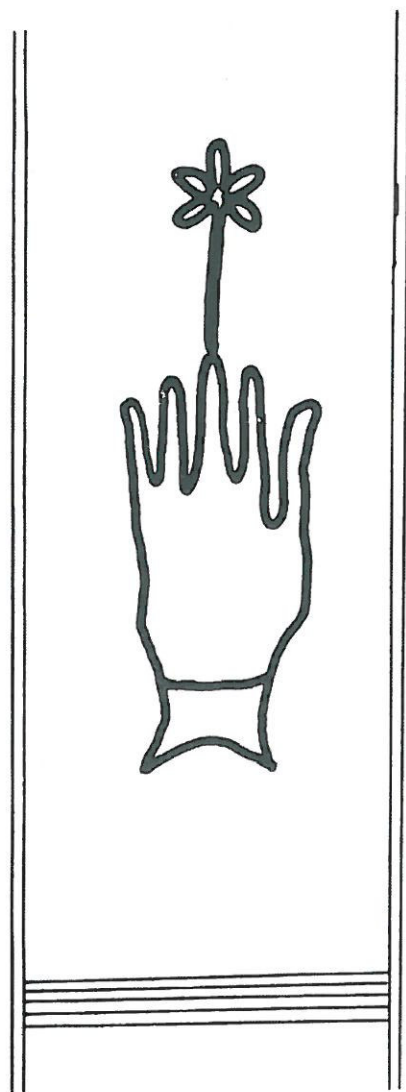

79. Incluida en ms. de 1384-1385, pero parece posterior (1).

MANO

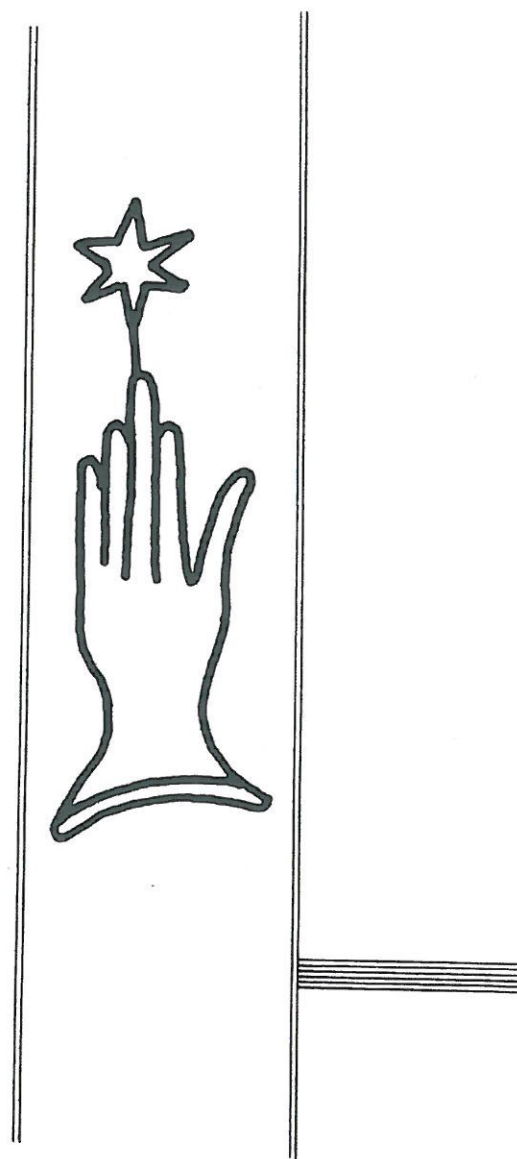

80. 1487-1488 (2).

MANO

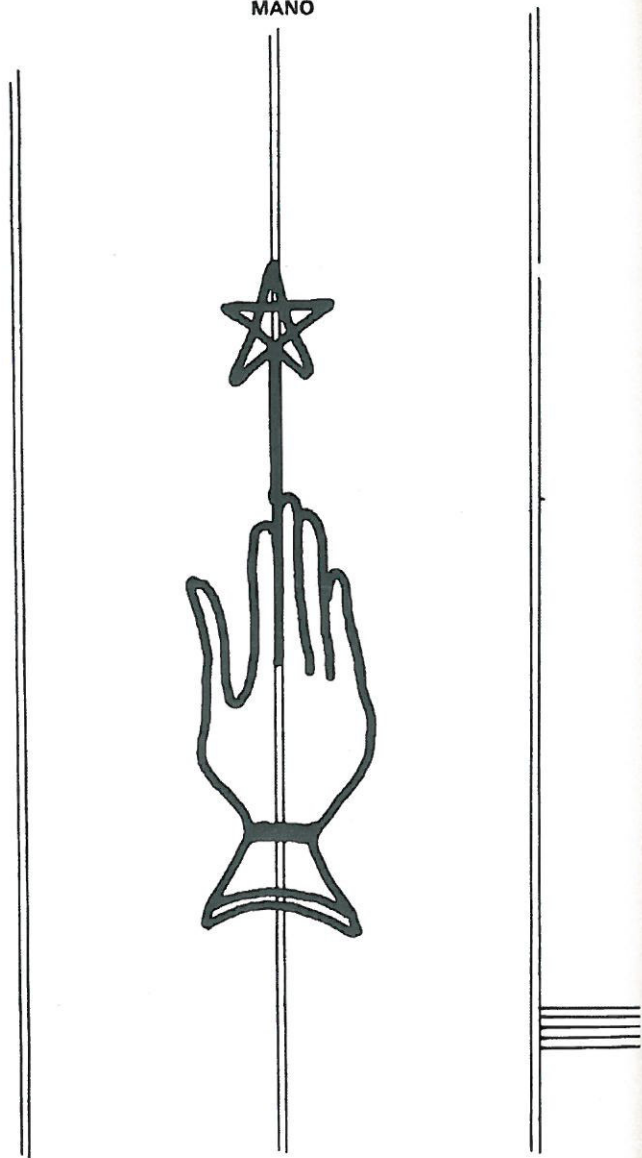

81. Dentro del ms. de 1384-1385, pero parece ser un apéndice introducido posteriormente.

MANO

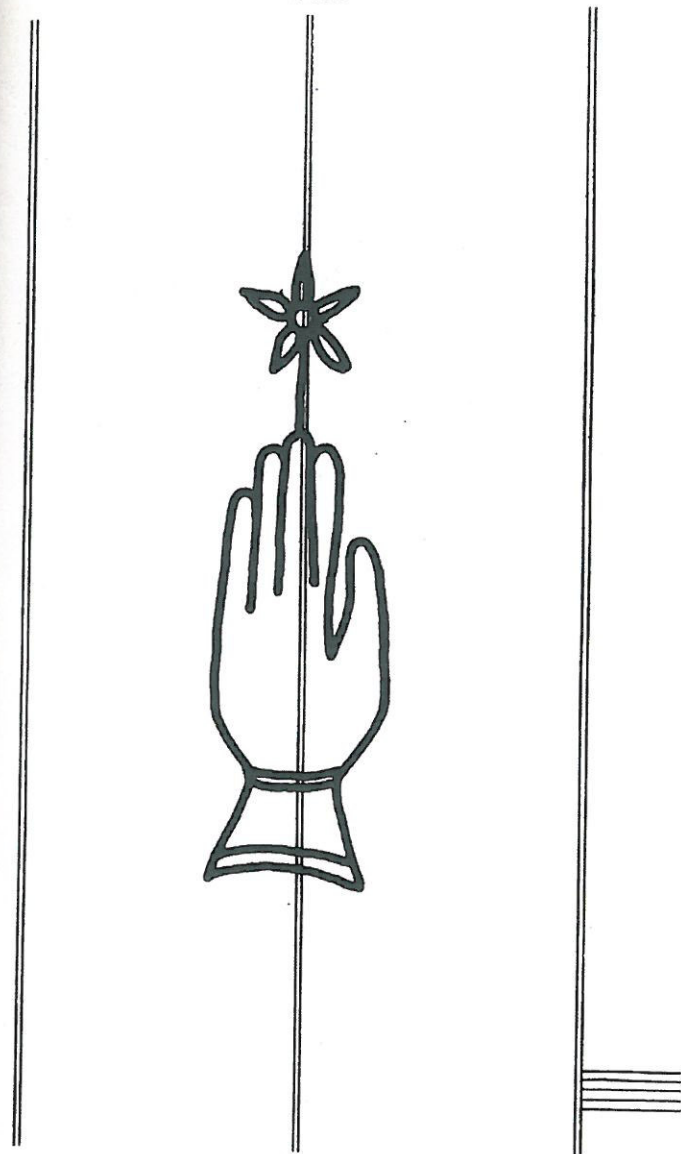

82. 1486-1487 (14) y 1489-1490 (9). Total: 23.

MANO

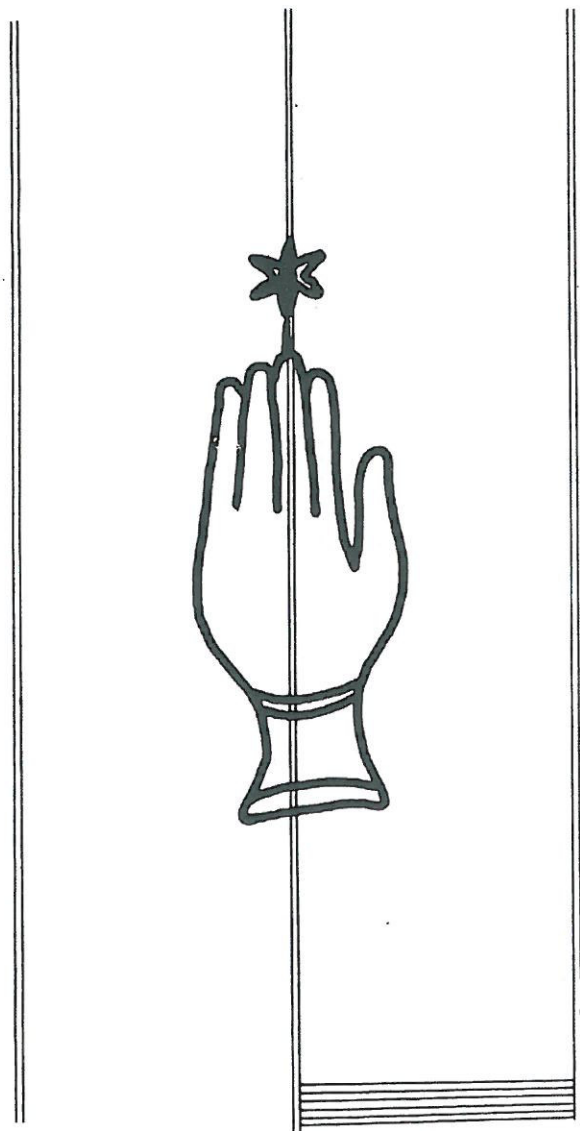

83. 1468-1469 (12); 1469-1470 (4); 1471-1472 (47) y 1472-1473 (51). Total: 114.

MANO

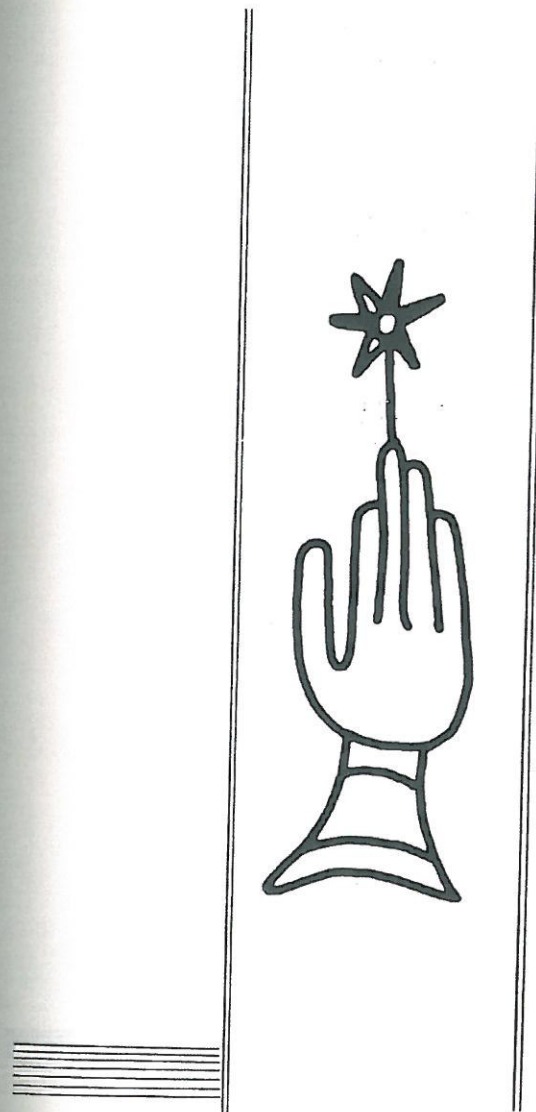

84. 1486-1487 (8).

MANO

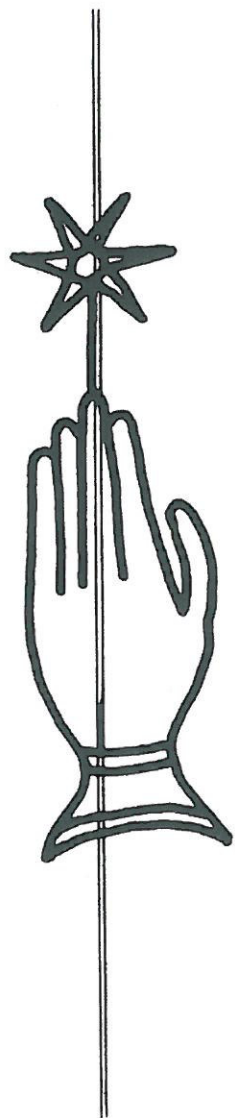

85. 1474-1475 (15) y 1480-1481 (22). Total: 37.

MANO



86. 1491-1492 (25) y 1492-1493 (20). Total: 45.

MANO

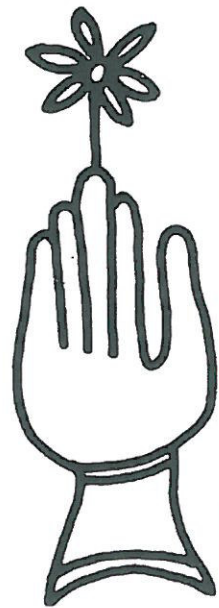

87. 1487-1488 (4); 1489-1490 (3) y 1490-1491 (15). Total: 22.

MANO

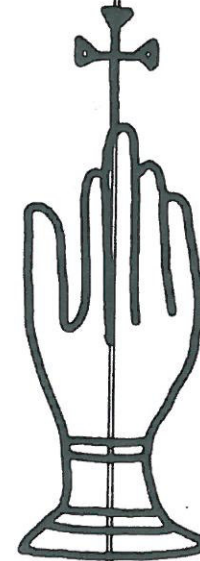

88. 1475-1476 (5).

MANO

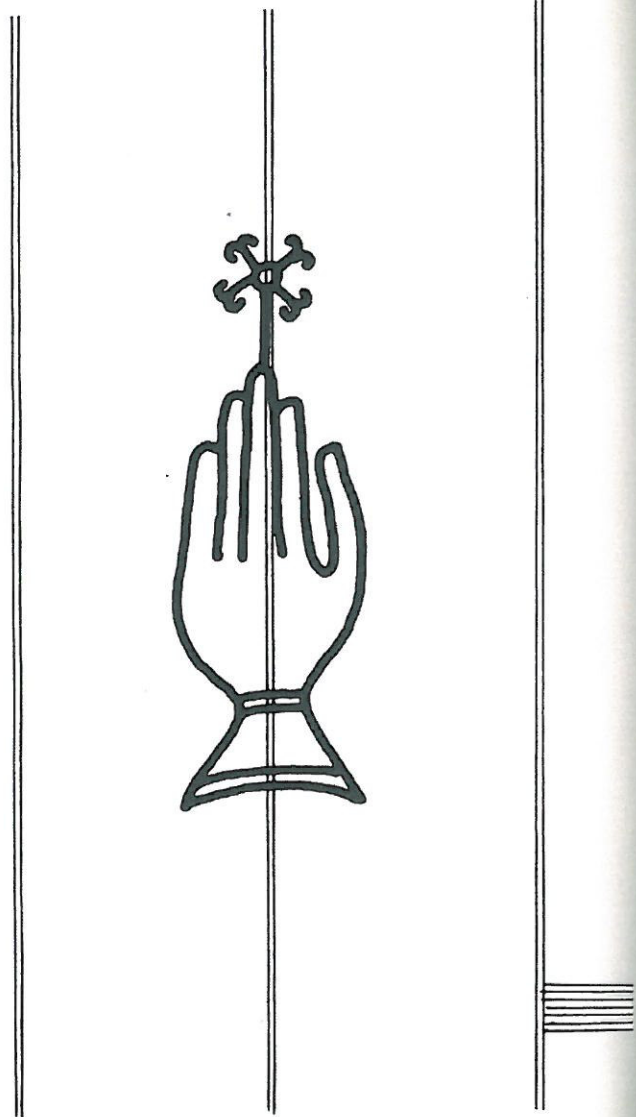

89. 1477-1478 (3).

MANO

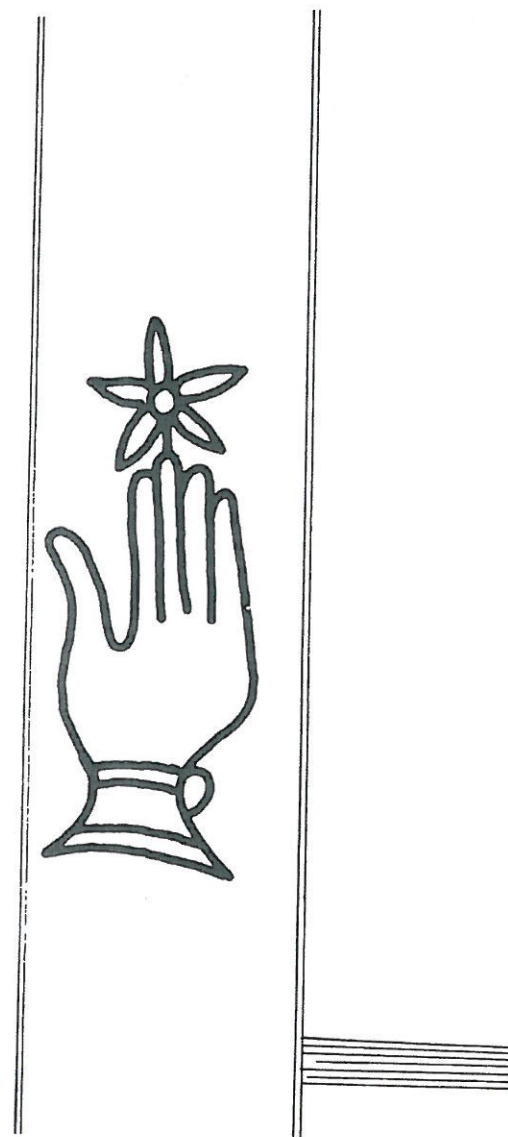

90. 1486-1487 (12) y 1488-1489 (4). Total: 16.

MANO

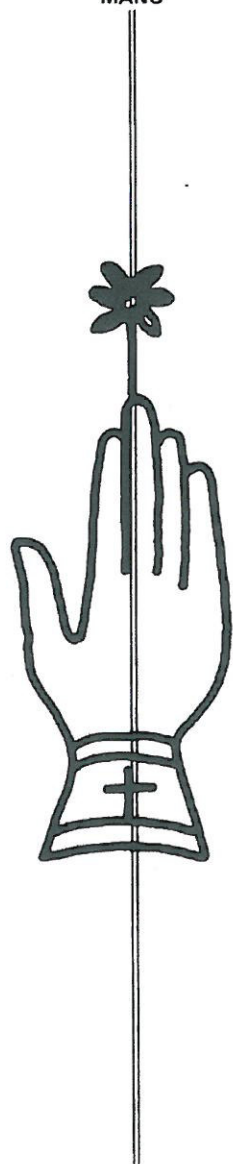

91. 1489-1490 (8) y 1492-1493 (3). Total: 11.

MANO

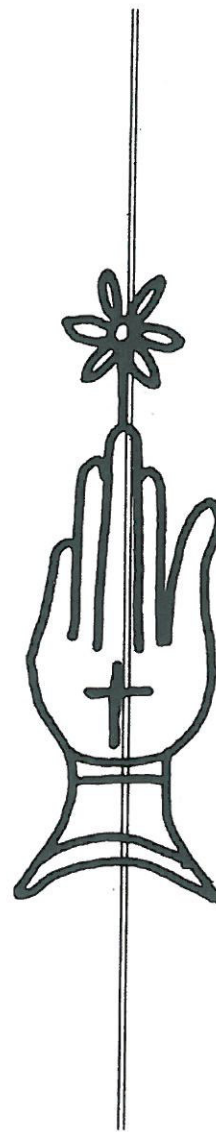

92. 1479-1480 (37).

MANO

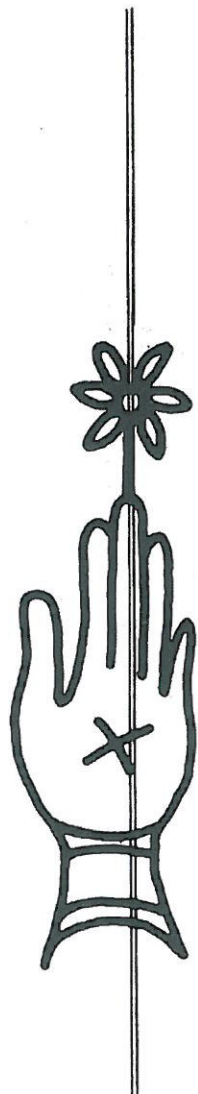

93. 1489-1490 (6).



MANO

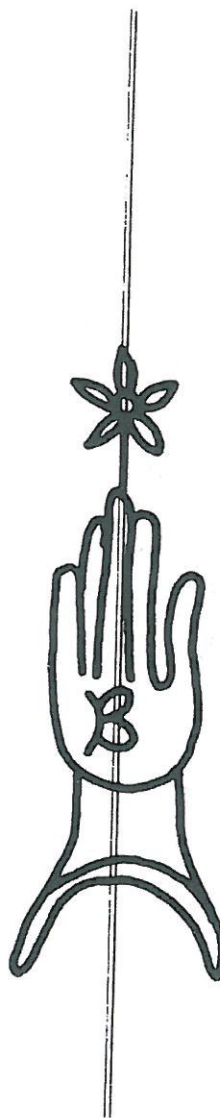

94. 1486-1487 (4).

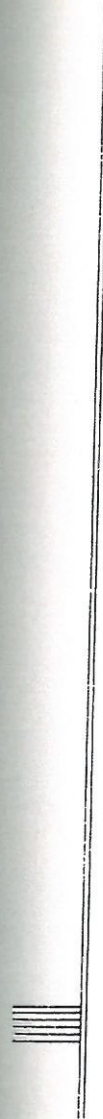

MANO

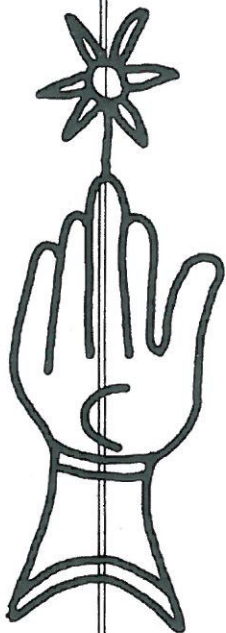

95. 1487-1488 (10); 1489-1490 (18); 1490-1491 (1) y 1492-1493 (2). Total: 31.

MANO



96. 1487-1488 (2); 1488-1489 (4) y 1490-1491 (6). Total: 12.

MANO

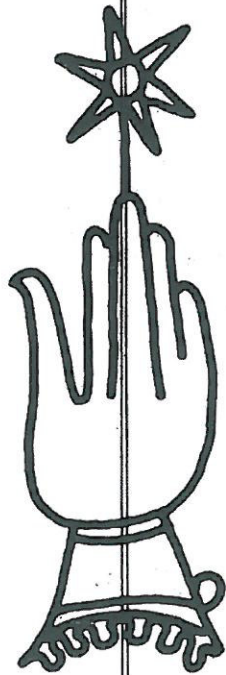

97. 1487-1488 (2); 1488-1489 (2); 1490-1491 (15); 1491-1492 (5) y 1492-1493 (3). Total: 27.

MANO

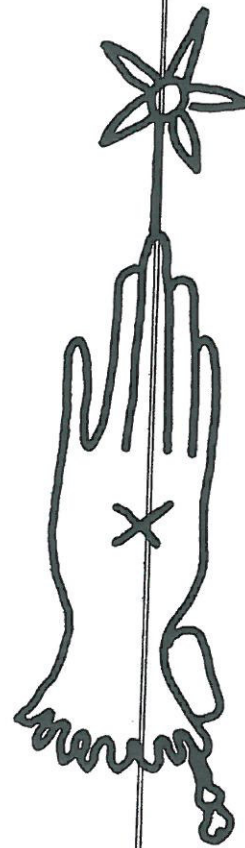

98. 1491-1492 (18) y 1492-1493 (17). Total: 35.

MANO

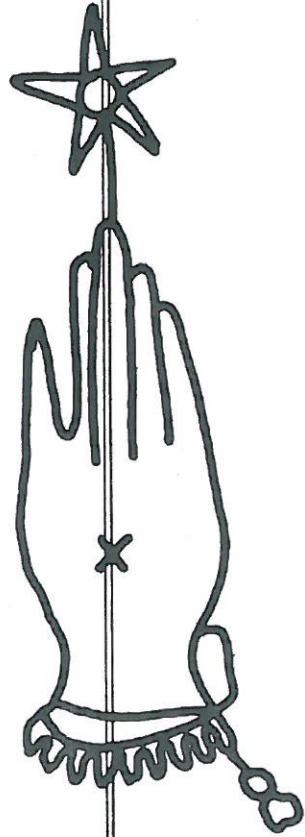

99. 1487-1488 (1) y 1492-1493 (8). Total: 9.

MANO

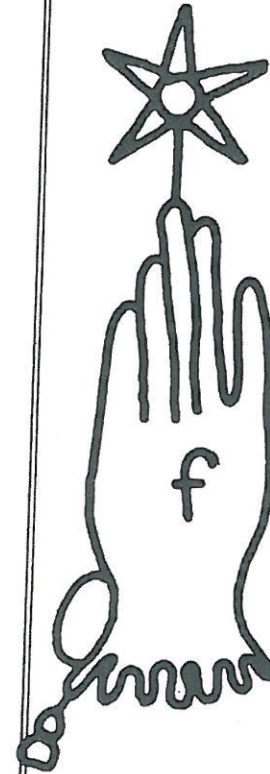

100. 1486-1487 (3); 1489-1490 (4) y 1490-1491 (6). Total: 13.

MONTES

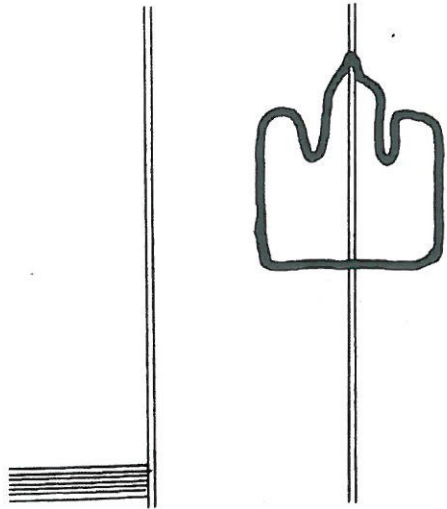

101. 1413-1414 (1).

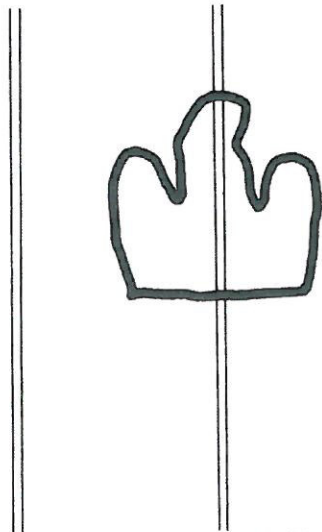

102. 1416-1417 (8).



MONTES

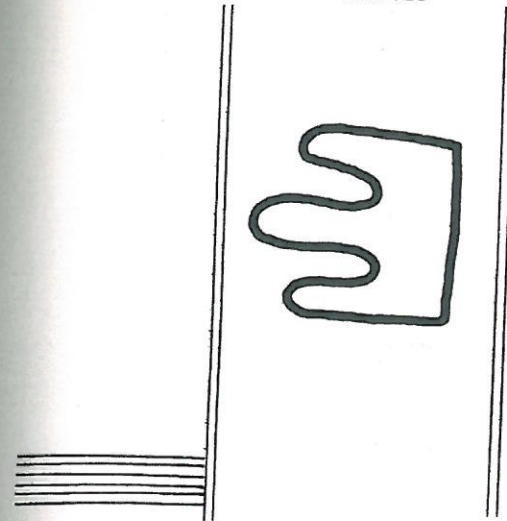

103. 1464-1465 (3).

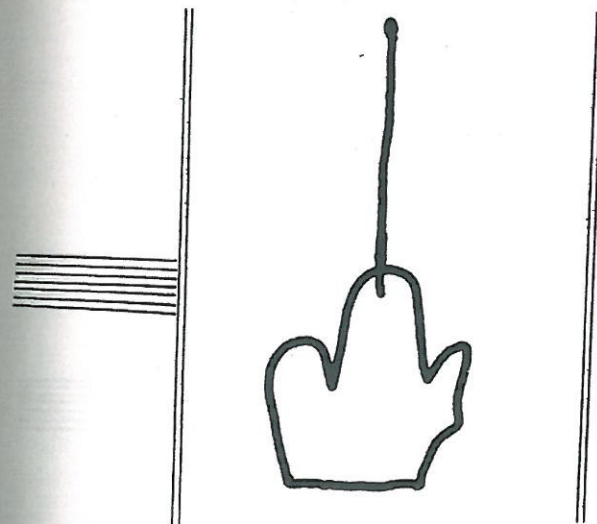

104. 1405-1406 (2) y 1416-1417 (17). Total: 19.

MONTES

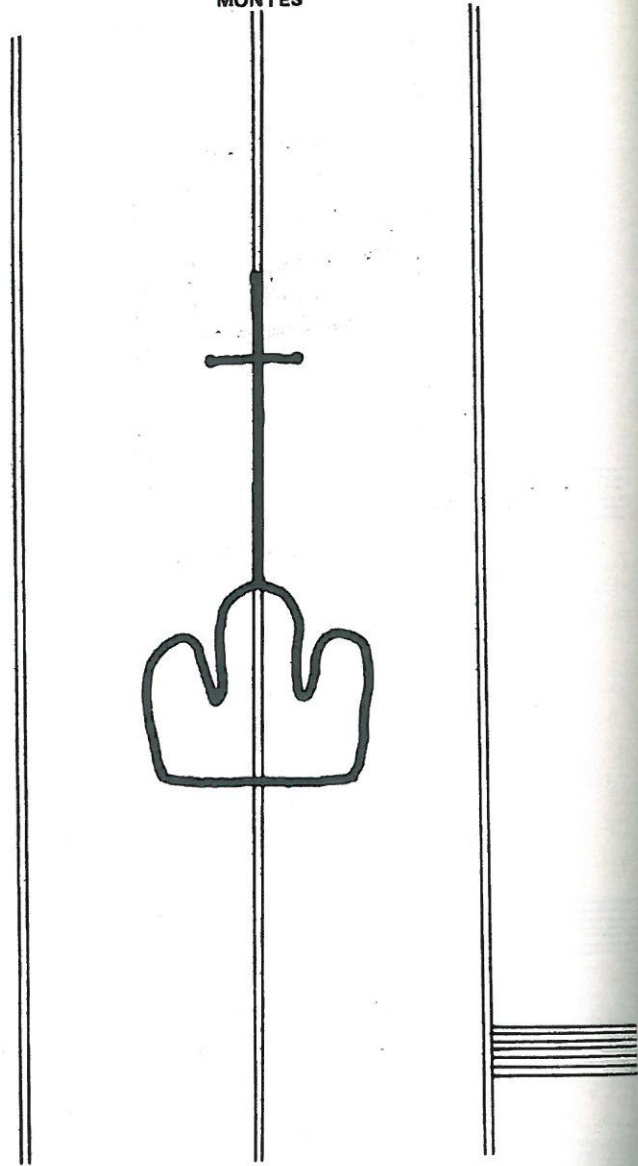

105. 1422-1423 (4); 1427-1428 (6) y 1438-1439 (36). Total: 46.

MONTES

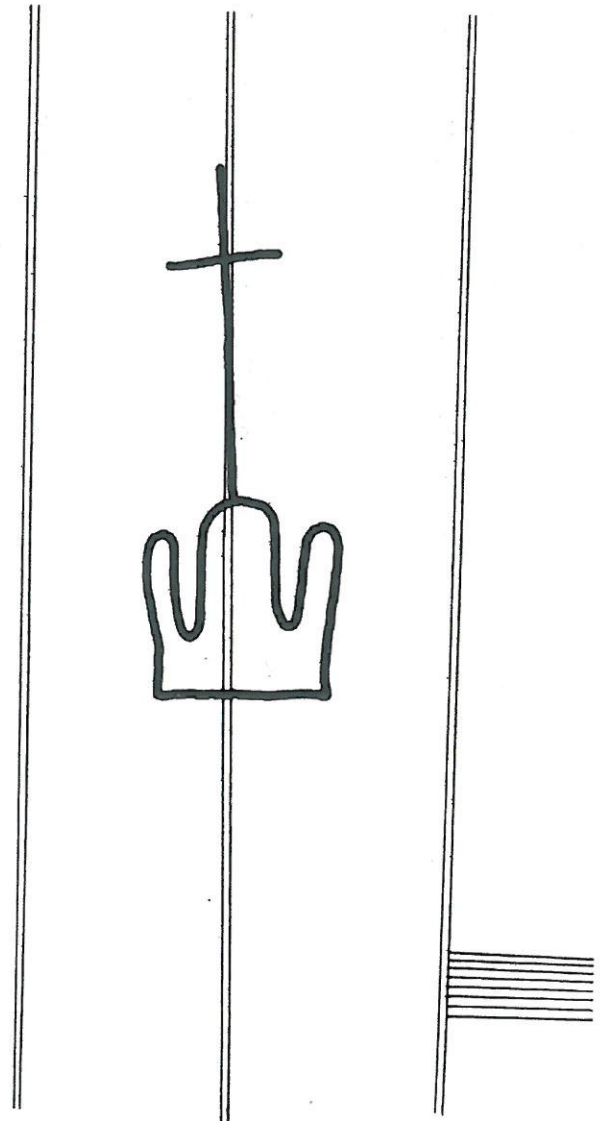

106. 1433-1434 (9) y 1436-1437 (1). Total: 10.

MONTES

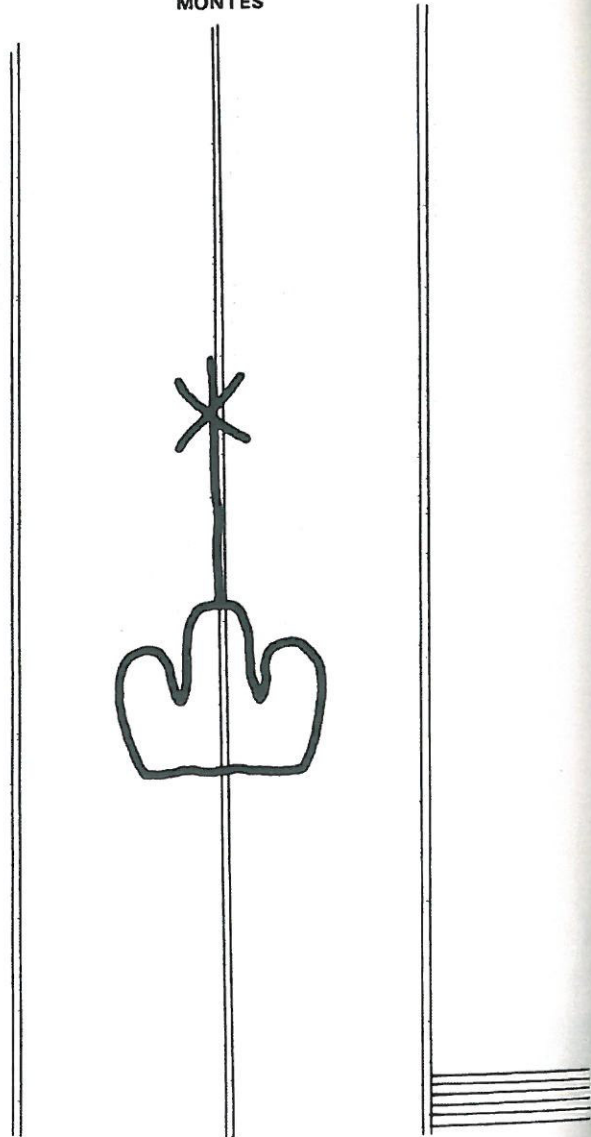

107. 1429-1430 (7) y 1463-1464 (1). Total: 8.

MONTES

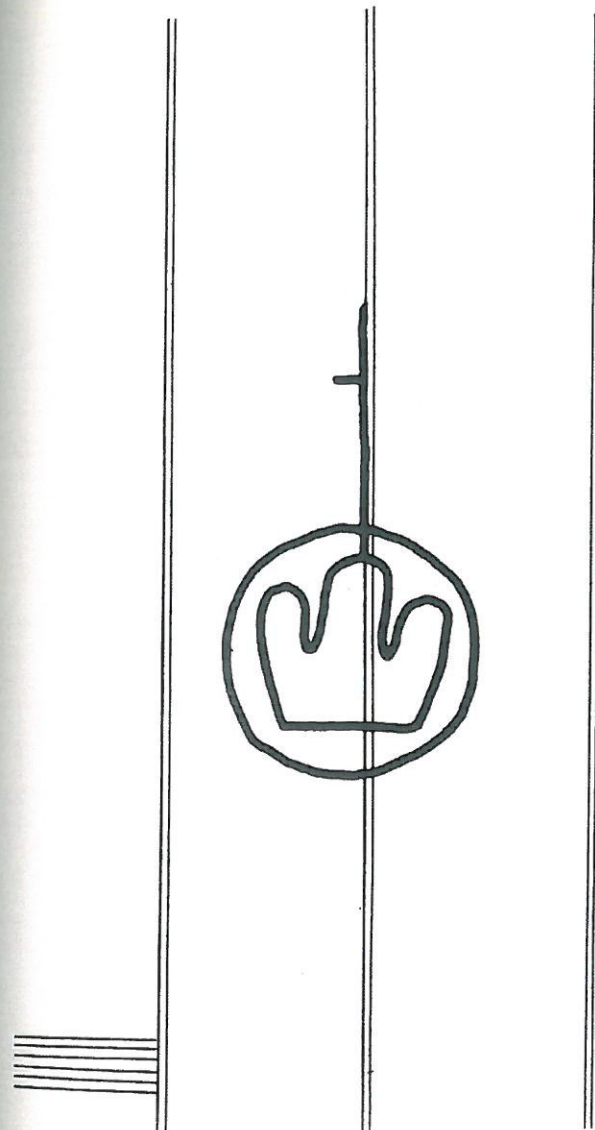

108. 1436-1437 (15); 1447-1448 (1) y 1448-1449 (7). Total: 23.

MONTES

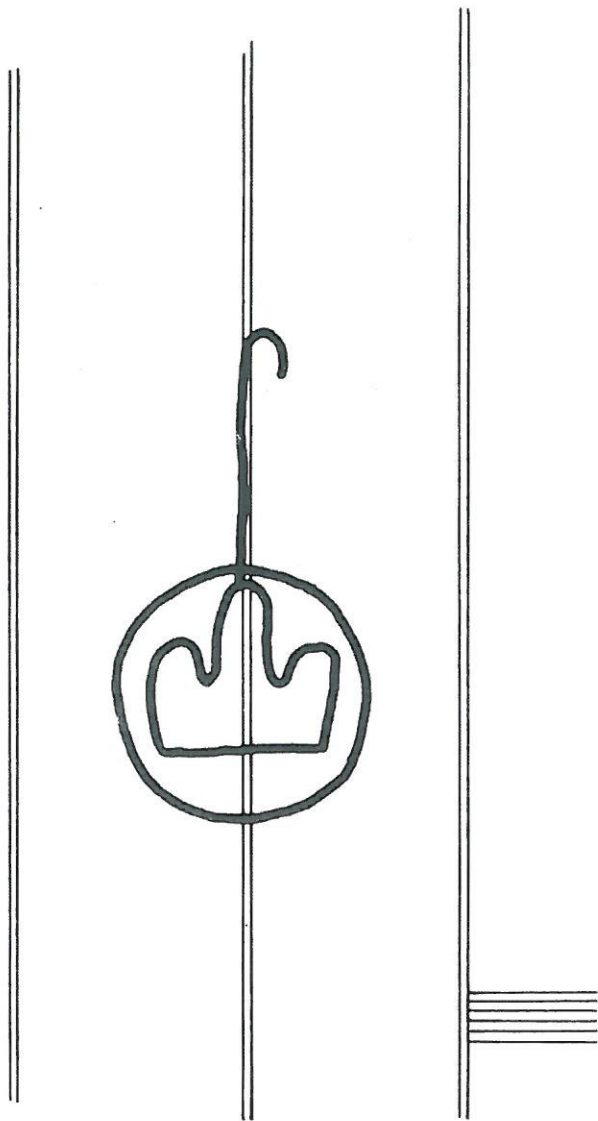

109. 1420-1421 (4) y 1436-1437 (10). Total: 14.

MONTES

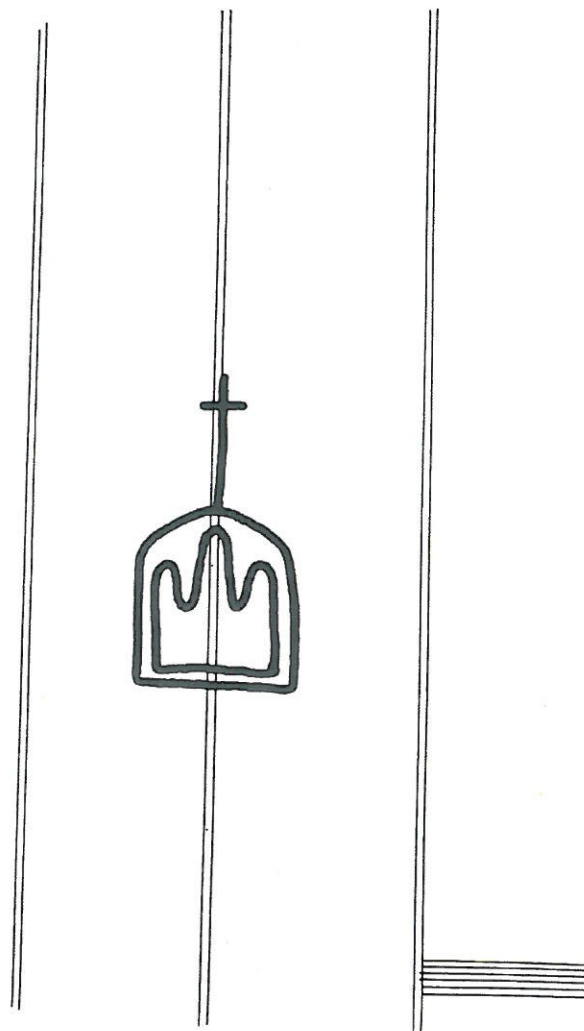

110. 1463-1464 (5) y 1464-1465 (3). Total: 8.

RUEDA

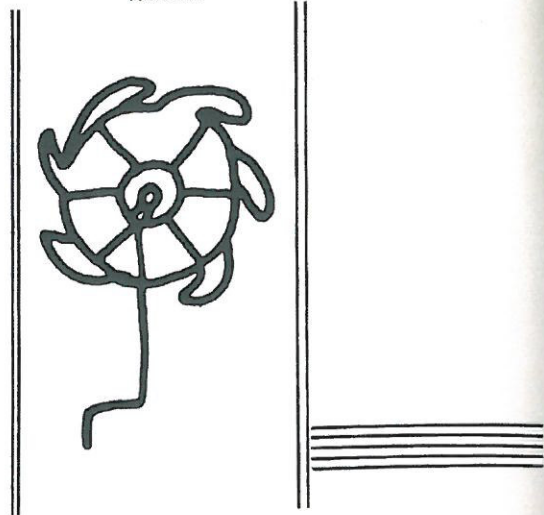

111. 1414-1415 (2).

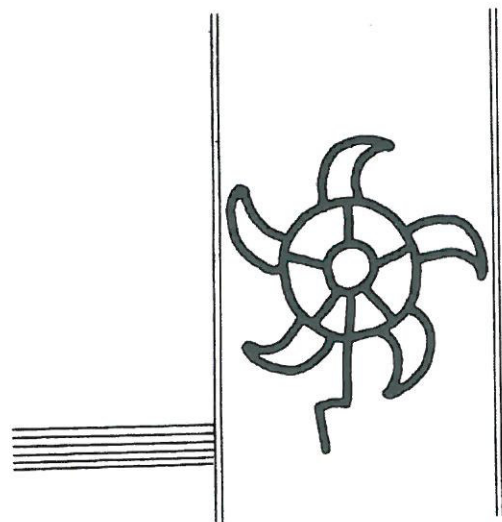

112. 1474-1475 (8) y 1475-1476 (33). Total: 41.

TIJERAS

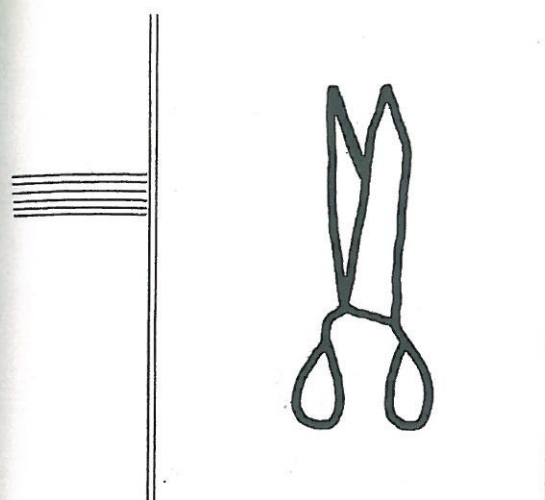

113. 1444-1445 (2) y 1445-1446 (3). Total: 5.

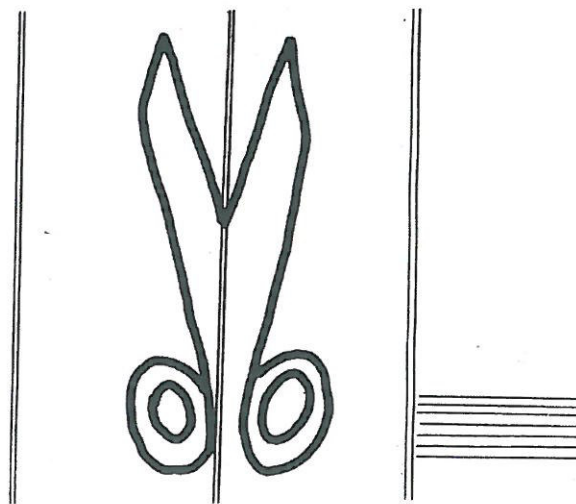

114. 1449-1450 (1) y 1477-1478 (1). Total: 2.

TIJERAS

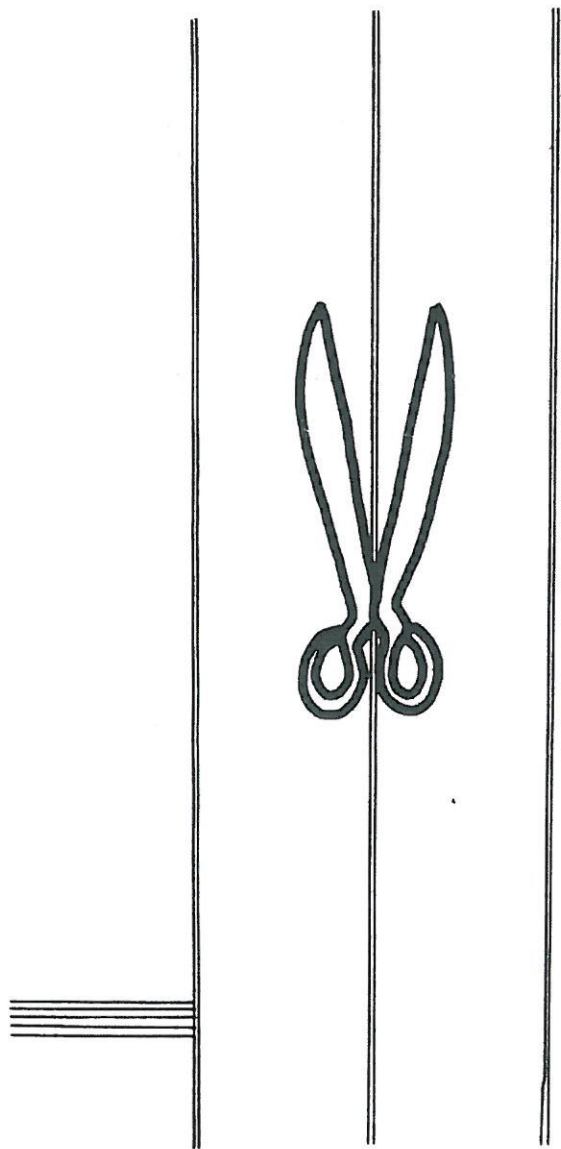

115. 1462-1463 (6).

TORRE

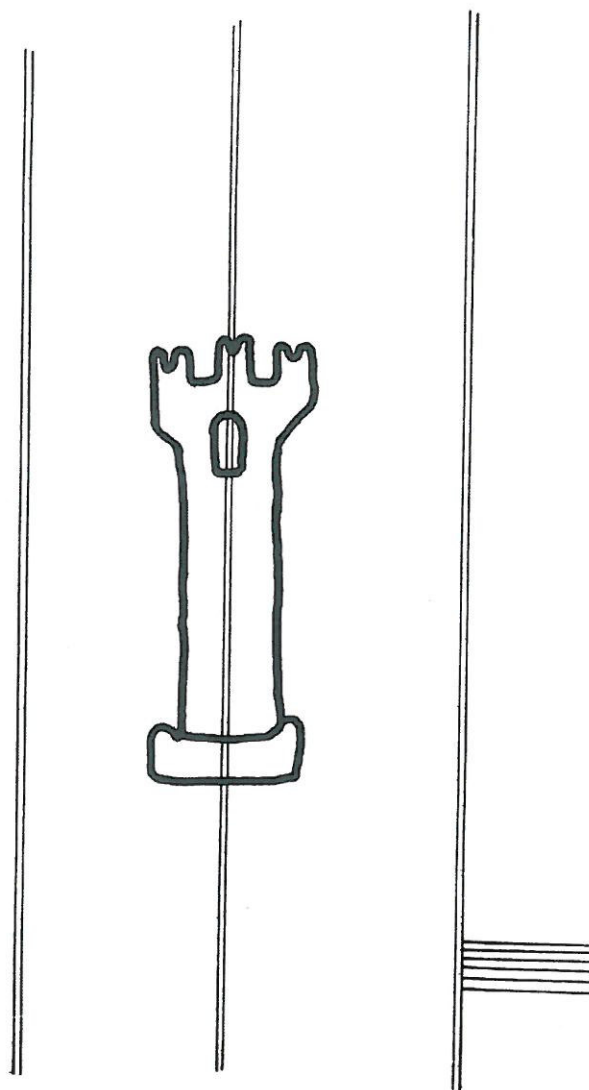

116. 1422-1423 (3).

TRIANGULO

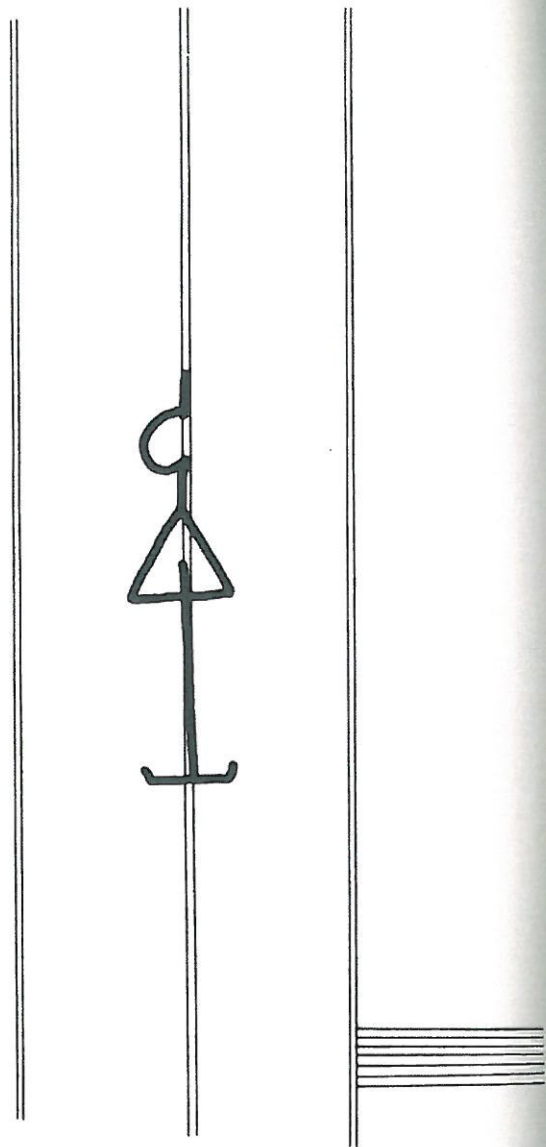

117. 1463-1464 (2).

UNICORNIO

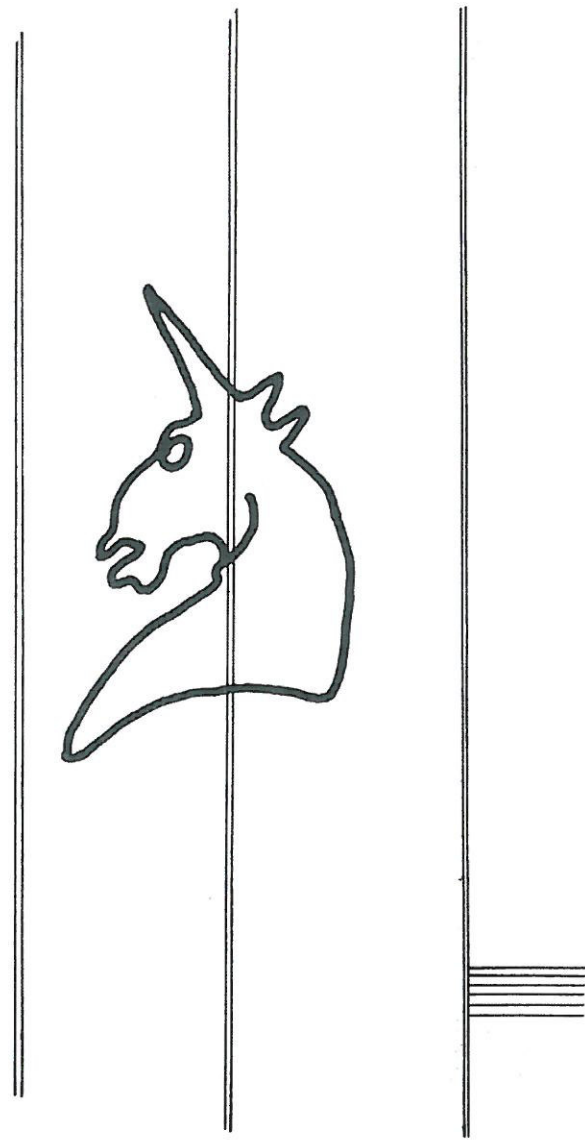

118. 1417-1418 (1) y 1419-1420 (14). Total: 15.

UNICORNIO

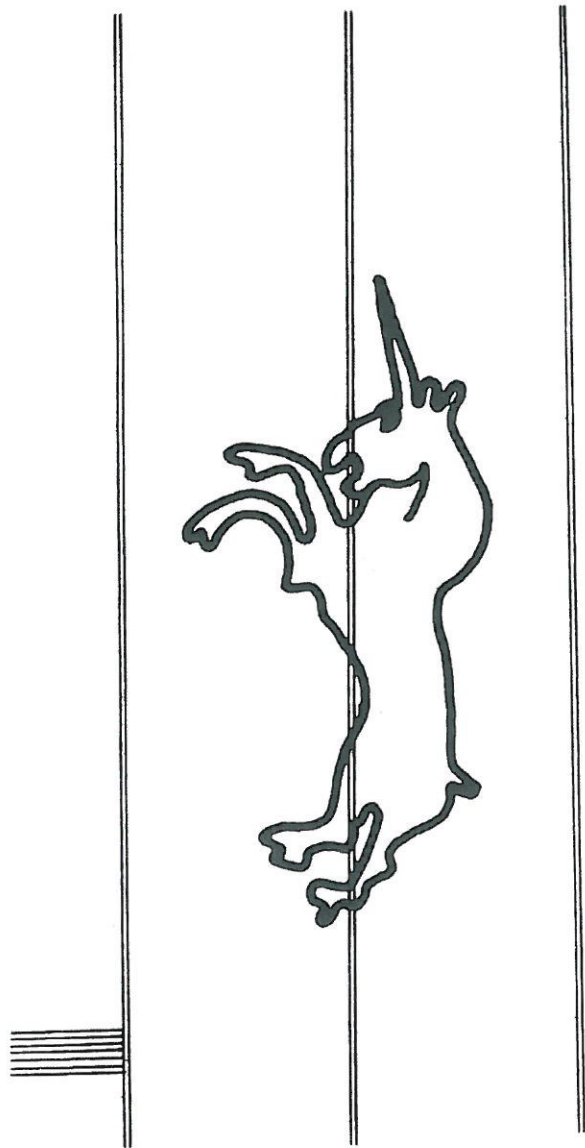

119. 1421-1422 (1).

UNICORNIO

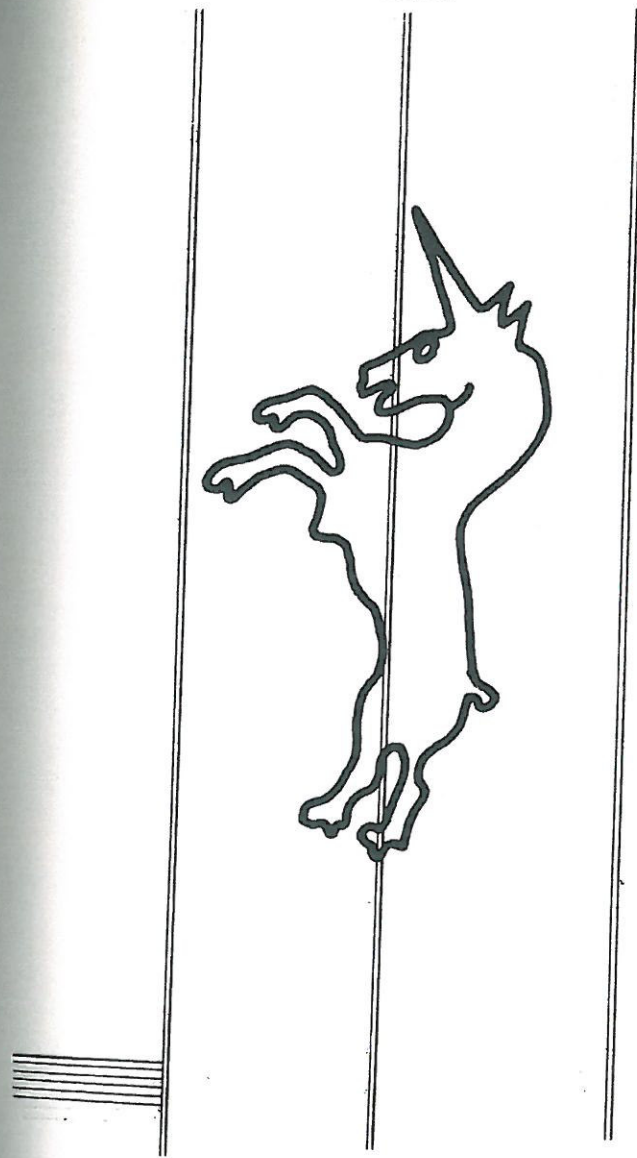

120. 1422-1423 (17); 1430-1431 (3) y 1431-1432 (1). Total: 21.

UNICORNIO

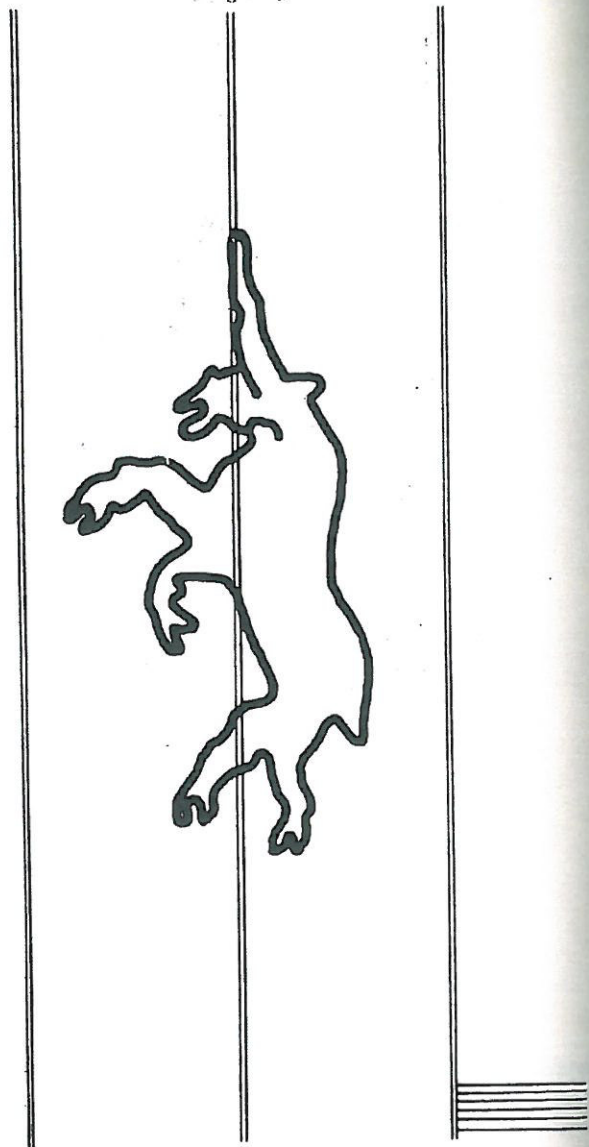

121. 1430-1431 (1).

UNICORNIO

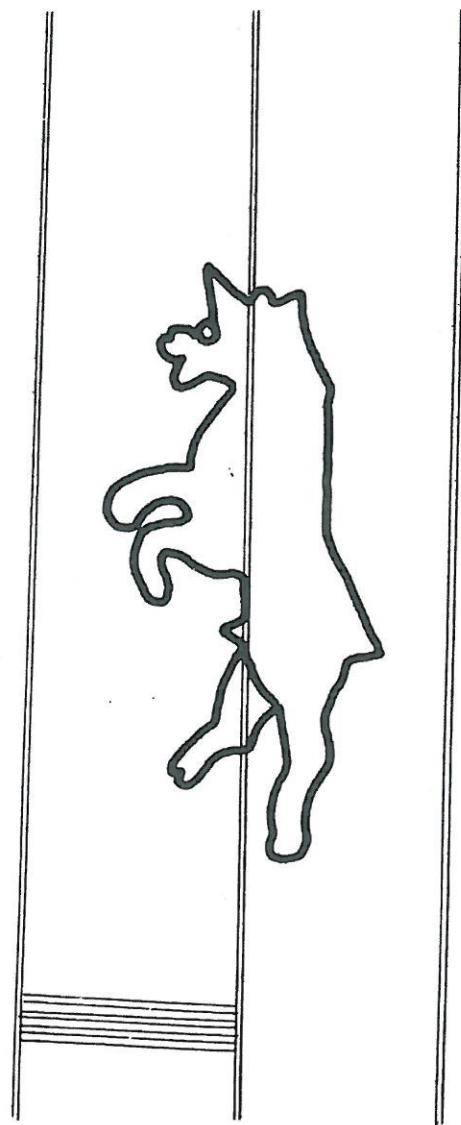

122. 1436-1437 (11).

UNICORNIO

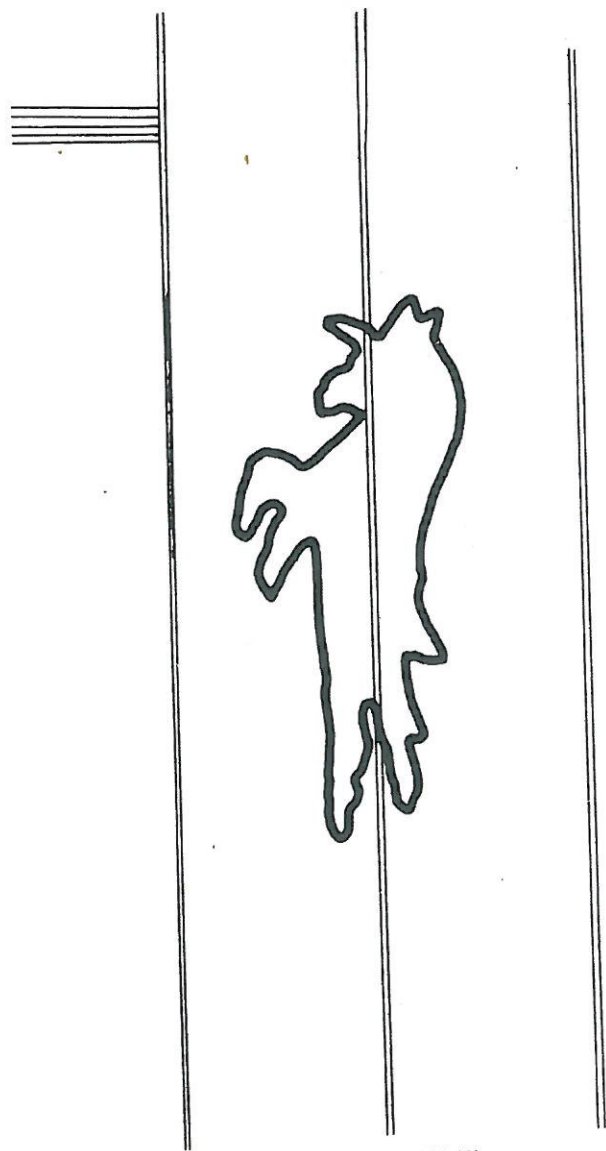

123. 1438-1439 (2).

INDETERMINADA

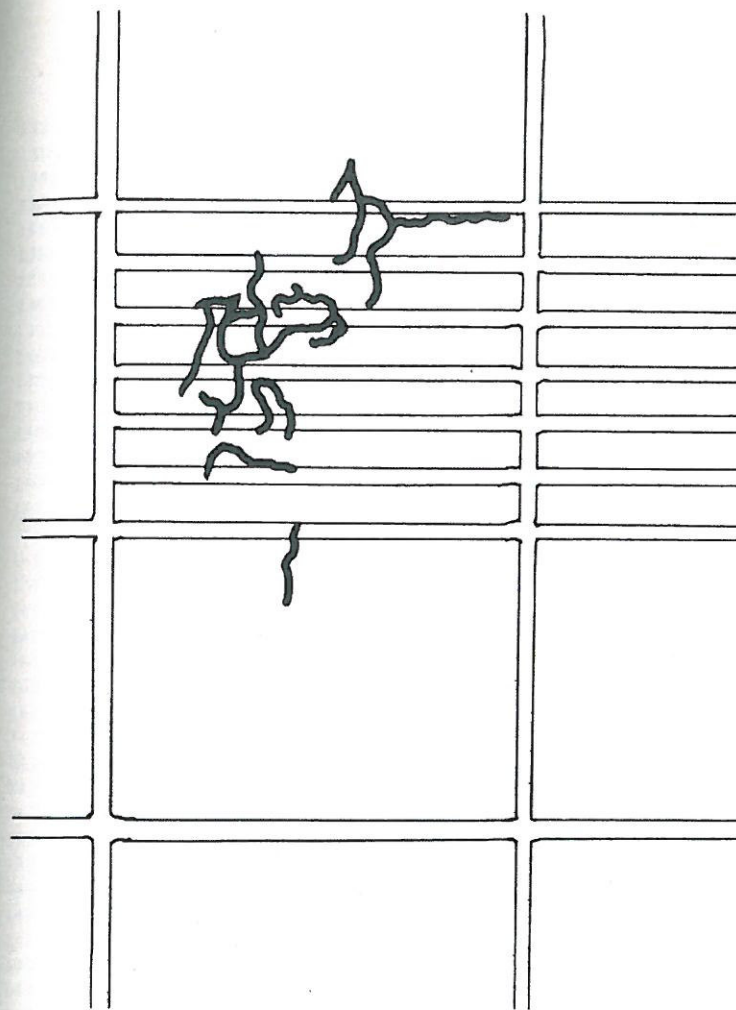

124. 1378-1379 (59); 1380-1381 (45); 1382-1383 (64); 1384-1385 (102);
 1385-1386 (112); 1386-1387 (104); 1389-1390 (101); 1391-1392 (71); 1392-
 1393 (58); 1400-1401 (73); 1403-1404 (93); 1404-1405 (79); 1408-1409
 (96); 1409-1410 (113) y 1411-1412 (122). Total: 1312.

INDICE DE MOTIVOS

Agnus Dei, 1 y 2.	Escudo, 52 a 54.
Aguila, 3.	Espada, 55 a 57.
Ancla, 4.	Estrella, 58.
Anillo, 5 y 6.	Flechas, 59.
Arco, 7 y 8.	Flor, 60 a 71.
Balanza, 9 a 12.	Inflorescencia, 72.
Basilisco, 13 a 15.	Letras, 73 a 75.
Bonete, 16 a 18.	Luna, 76.
Buey, 19 a 24.	Llaves, 77.
Caballo, 25.	Mano, 78 a 100.
Cabeza Humana, 26.	Montes, 101 a 110.
Campana, 27.	Rueda, 111 a 112.
Cantimplora, 28.	Tijeras, 113 a 115.
Carro, 29 a 36.	Torre, 116.
Castillo, 37.	Triángulo, 117.
Círculo, 38 y 39.	Unicornio, 118 a 123.
Ciervo, 40 y 41.	Indeterminada, 124.
Columna, 42.	
Corona, 43.	
Cruz, 44 y 45.	
Cuerno, 46 a 49.	
Dragón, 50 y 51.	

INDICE CRONOLOGICO

1378/79: 124.	1444: 4, 27, 29 y 113.
1380: 124.	1445: 4, 29 y 113.
1382: 124.	1447: 46 y 108.
1384: 79, 81 y 124.	1448: 4, 49 y 108.
1385: 124.	1449: 4, 48 y 114.
1386: 124.	1450/51: 10 y 21.
1389: 124.	1451/52: 55 a 57.
1391: 124.	1452: 53, 68, 69 y 72.
1392: 124.	1454: 11 y 50.
1400: 3, 7 y 124.	1455: 1, 2 y 11.
1403: 124.	1456: 5.
1404: 124.	1457: 5.
1405: 77 y 124.	1458: 17, 23 y 34.
1408: 124.	1459: 10, 23, 33, 34 y 64.
1409/10: 124.	1460: 5, 70 y 71.
1411: 124.	1462: 18, 33, 37, 45, 47, 51 y 115.
1413: 27 y 101.	1463: 14, 37, 59, 65, 66, 107, 110 y 117.
1414: 27, 31 y 111.	1464: 15, 20, 59, 75, 103 y 110.
1416: 38, 39, 52, 102 y 104.	1468: 5, 20, 36, 59 y 83.
1417: 4, 13, 28 y 118.	1469: 19, 24, 30, 35, 43 y 83.
1419: 40 y 118.	1470/71: 32 y 67.
1420/21: 31, 79 y 109.	1471: 83.
1421: 48, 60 y 119.	1472: 83.
1422: 60, 105, 116 y 120.	1473: 22 y 62.
1423: 4, 31 y 74.	1474: 85 y 112.
1424: 42.	1475: 78, 88 y 112.
1427: 4, 16, 27, 31 y 105.	1477: 78, 89 y 114.
1429: 52 y 107.	1478: 54.
1430/31: 8, 120 y 121.	1479: 6 y 92.
1431: 25, 41, 52 y 120.	1480: 85.
1433: 106.	1486: 82, 84, 90, 94 y 100.
1435: 4 y 9.	1487: 80, 87, 95, 96, 97 y 99.
1436: 58, 106, 108, 109 y 122.	1488: 26, 90, 96 y 97.
1437: 76.	1489: 5 y 100.
1438: 61, 76, 105 y 123.	1490/91: 87, 95, 96, 97, 98 y 100.
1439: 4 y 44.	1491: 86, 97 y 98.
1443: 4 y 27.	1492: 86, 91, 95, 97 y 99.