



CERN-TH.6070/91
NUHEP-TH-91-8
PM/91-8

QCD ANALYSIS OF THE TAU HADRONIC WIDTH

E.Braaten ^{a)}, S.Narison ^{b)} and A.Pich ^{c,*}

a) Department of Physics and Astronomy, Northwestern University, Evanston, Illinois 60208

b) Laboratoire de Physique Mathématique, U.S.T.L., 34060 Montpellier Cedex, France

c) Theoretical Physics Division, CERN, CH-1211 Geneva 23, Switzerland

ABSTRACT

The total τ hadronic width can be accurately calculated using analyticity and the operator product expansion. The theoretical analysis of this observable is updated to include all available perturbative and nonperturbative corrections. Experimental measurements of τ decay rates are used to determine with high precision the QCD running coupling constant at the scale of the τ mass. The analysis is also used to study the present discrepancy between the experimental measurements of the leptonic branching fractions of the τ and its total lifetime.

*) On leave of absence from Departament de Física Teòrica, Universitat de València, and IFIC, Centre Mixte Universitat de València - CSIC, E-46100 Burjassot (València), Spain.

CERN-TH.6070/91
NUHEP-TH-91-8
PM/91-8
September 1991

1. INTRODUCTION

The τ is the only presently known lepton heavy enough to decay into hadrons. Its semileptonic decays are an ideal tool for studying the hadronic weak currents under very clean conditions [1]. Moreover, the inclusive character of the total τ hadronic width makes it possible to do an accurate theoretical calculation of this observable using standard field theoretic methods [2-7]. Our aim in this paper is to present a detailed analysis within the standard model of all the contributions to the τ hadronic width, taking into account additional higher-order corrections to the results previously discussed in the literature. This analysis will be used to provide an updated determination of the QCD running coupling constant $\alpha_s(M_\tau)$ at the scale of the τ mass. It will also be used to study the present discrepancy [8,9] between measurements of the leptonic branching fractions and the total lifetime of the τ .

We shall be primarily concerned with the ratio

$$R_\tau \equiv \frac{\Gamma(\tau^- \rightarrow \nu_\tau \text{hadrons}(\gamma))}{\Gamma(\tau^- \rightarrow \nu_\tau e^- \bar{\nu}_e(\gamma))}, \quad (1.1)$$

where (γ) represents possible additional photons or lepton pairs. If strong and electroweak radiative corrections are ignored and if the masses of final state particles are neglected, the universality of the W-coupling to the fermionic charged currents implies that this ratio should be

$$R_\tau^{\text{naive}} = N_c (|V_{ud}|^2 + |V_{us}|^2) \simeq 3, \quad (1.2)$$

which compares reasonably well with the formal experimental average [9] $R_\tau^{\text{exp}} = 3.61 \pm 0.05$. This provides strong evidence for the colour degree of freedom N_c . We will show in the following that QCD dynamics is able to account quantitatively for the difference between the naive prediction and the measured value of R_τ .

The experimental value for R_τ is actually determined by measuring the leptonic branching fractions:

$$R_\tau^{\text{exp},B} \equiv \frac{1 - B_e - B_\mu}{B_e}, \quad (1.3)$$

where $B_\ell = \Gamma(\tau^- \rightarrow \nu_\tau \ell^- \bar{\nu}_\ell(\gamma))/\Gamma_\tau$ and Γ_τ is the total decay rate. The branching fractions are measured by accumulating a large number of τ decay events, counting the number of decays into specific channels, and correcting for various experimental biases. An independent determination of R_τ can be obtained by measuring the lifetime $1/\Gamma_\tau$:

$$R_\tau^{\text{exp},\Gamma} \equiv \frac{\Gamma_\tau - \Gamma_{\tau \rightarrow e} - \Gamma_{\tau \rightarrow \mu}}{\Gamma_{\tau \rightarrow e}}, \quad (1.4)$$

where $\Gamma_{\tau \rightarrow \ell} = \Gamma(\tau^- \rightarrow \nu_\tau \ell^- \bar{\nu}_\ell(\gamma))$. Because the decays $\tau^- \rightarrow \nu_\tau \ell^- \bar{\nu}_\ell(\gamma)$ are purely electroweak processes, their rates can be calculated theoretically with great accuracy. The only unknown in (1.4) is therefore the total decay rate Γ_τ . It is measured by collecting a

large sample of τ decay events and measuring the distribution of the decay lengths of the τ . This measurement of R_τ is therefore completely independent of the branching fraction measurement (1.3). The present results [9] for these two independent determinations of R_τ are

$$R_\tau^{exp,B} = 3.66 \pm 0.05, \quad (1.5a)$$

$$R_\tau^{exp,\Gamma} = 3.32 \pm 0.12, \quad (1.5b)$$

which differ by about two standard deviations. The experimental number quoted before, $R_\tau^{exp} = 3.61 \pm 0.05$, is just the formal average of (1.5a) and (1.5b).

We will show conclusively in this paper that the uncertainties in the theoretical calculation of R_τ are quite small. The value of R_τ can then be accurately predicted as a function of $\alpha_s(M_\tau)$. Alternatively, measurements of inclusive τ decay rates can be used to determine the value of the QCD running coupling $\alpha_s(M_\tau)$ at the scale of the τ mass. In fact, τ decay is probably the lowest energy process from which the running coupling constant can be extracted cleanly without hopeless complications from nonperturbative effects. As we shall see in this paper, the τ mass $M_\tau = 1.784 \text{ GeV}$ lies fortuitously in a “compromise” region where the coupling constant $\alpha_s(M_\tau)$ is large enough that R_τ is sensitive to its value, yet still small enough that the perturbative expansion in powers of $\alpha_s(M_\tau)$ still converges well. Moreover, as will be shown, the nonperturbative contributions to the total τ -hadronic width are very small.

It is the inclusive nature of the total semihadronic decay rate that makes a rigorous theoretical calculation of R_τ possible. The only separate contributions to R_τ that can be calculated are those associated with specific quark currents. We can calculate the nonstrange and strange contributions to R_τ , and resolve these further into vector and axial vector contributions. Since strange decays can not be resolved experimentally into vector and axial vector contributions, we will decompose our predictions for R_τ into only three categories:

$$R_\tau = R_{\tau,V} + R_{\tau,A} + R_{\tau,S}. \quad (1.6)$$

Nonstrange semihadronic decays of the τ are resolved experimentally into vector ($R_{\tau,V}$) and axial vector ($R_{\tau,A}$) contributions according to whether the hadronic final state includes an even or odd number of pions. Strange decays ($R_{\tau,S}$) are of course identified by the presence of an odd number of kaons in the final state. The naive predictions for these three ratios are $R_{\tau,V} = R_{\tau,A} = (N_c/2)|V_{ud}|^2$ and $R_{\tau,S} = N_c|V_{us}|^2$, which add up to (1.2).

The outline of the remainder of this paper is as follows. In section 2, we describe the theoretical framework in which the ratio R_τ is calculated. In section 3, we collect together all the QCD corrections to R_τ . They include the perturbative QCD corrections neglecting quark masses (section 3.1), the leading quark-mass corrections (section 3.2), and QCD corrections of dimensions 4 (section 3.3), 6 (section 3.4), and higher (section 3.5). In section 4, we present the electroweak corrections. Section 5 contains a detailed numerical analysis of all the contributions. Our phenomenological predictions and conclusions will

be summarized in section 6. Our calculations make use of a number of previous results on the operator product expansion (OPE) for current-current correlation functions which are collected together into two appendices. Appendix A is a compendium of the Wilson coefficients for this expansion, including next to leading order corrections. Appendix B describes the basis of dimension 4 operators which have the required scaling and factorization properties.

2. THEORETICAL FRAMEWORK

The theoretical analysis of the inclusive semihadronic decay rate of the τ begins with the two-point correlation functions for the vector $V_{ij}^\mu = \bar{\psi}_j \gamma^\mu \psi_i$ and axial vector $A_{ij}^\mu = \bar{\psi}_j \gamma^\mu \gamma_5 \psi_i$ color singlet quark currents:

$$\Pi_{ij,V}^{\mu\nu}(q) \equiv i \int d^4x e^{iqx} \langle 0 | T(V_{ij}^\mu(x) V_{ij}^\nu(0)^\dagger) | 0 \rangle, \quad (2.1a)$$

$$\Pi_{ij,A}^{\mu\nu}(q) \equiv i \int d^4x e^{iqx} \langle 0 | T(A_{ij}^\mu(x) A_{ij}^\nu(0)^\dagger) | 0 \rangle. \quad (2.1b)$$

Here, the subscripts $i, j = u, d, s$ denote light quark flavours. The vector (V) and axial vector (A) correlators in (2.1) have the Lorentz decompositions

$$\Pi_{ij,V/A}^{\mu\nu}(q) = (-g^{\mu\nu} q^2 + q^\mu q^\nu) \Pi_{ij,V/A}^{(1)}(q^2) + q^\mu q^\nu \Pi_{ij,V/A}^{(0)}(q^2), \quad (2.2)$$

where the superscript (J) denotes the angular momentum $J = 1$ or $J = 0$ in the hadronic rest frame.

The imaginary parts of the correlators $\Pi_{ij,V/A}^{(J)}(q^2)$ defined in (2.2) are proportional to the spectral functions for hadrons with the corresponding quantum numbers. The semihadronic decay rate of the τ can be written as an integral of these spectral functions over the invariant mass s of the final state hadrons:

$$R_\tau = 12\pi \int_0^{M_\tau^2} \frac{ds}{M_\tau^2} \left(1 - \frac{s}{M_\tau^2}\right)^2 \left[\left(1 + 2\frac{s}{M_\tau^2}\right) \text{Im}\Pi^{(1)}(s + i\epsilon) + \text{Im}\Pi^{(0)}(s + i\epsilon) \right]. \quad (2.3)$$

The appropriate combinations of correlators are

$$\Pi^{(J)}(s) \equiv |V_{ud}|^2 \left(\Pi_{ud,V}^{(J)}(s) + \Pi_{ud,A}^{(J)}(s) \right) + |V_{us}|^2 \left(\Pi_{us,V}^{(J)}(s) + \Pi_{us,A}^{(J)}(s) \right). \quad (2.4)$$

Since the hadronic spectral functions are sensitive to the nonperturbative effects of QCD that bind quarks into hadrons, the integrand of (2.3) can not be calculated at present in any systematic way¹. Nevertheless the integral itself can be calculated systematically by exploiting the analytic properties of the correlators $\Pi^{(J)}(s)$ [11]. They are analytic

¹ Some early attempts to estimate the high-energy region can be found in ref. [10].

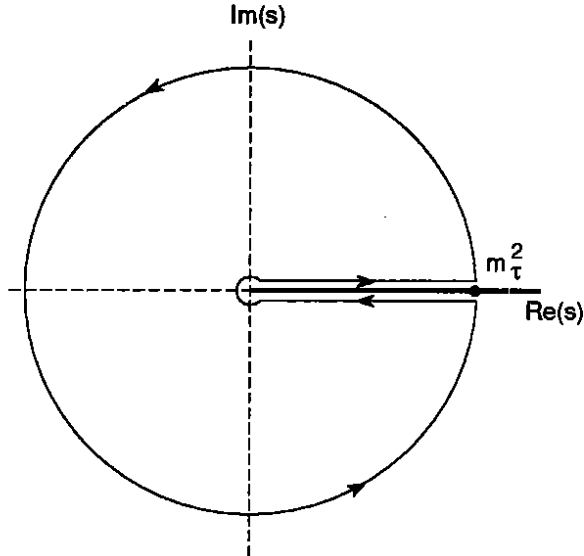

Fig.1. Integration contour in the complex s -plane, used to obtain eq. (2.5).

functions of s except along the positive real s -axis, where their imaginary parts have discontinuities. The integral (2.3) can therefore be expressed as a contour integral running from $s = M_\tau^2 - i\epsilon$ below the axis to $s = M_\tau^2 + i\epsilon$ above the axis. By analyticity, the integral along the entire contour in Figure 1 vanishes. Thus R_τ can be expressed as an integral around the contour that runs counter-clockwise around the circle $|s| = M_\tau^2$:

$$R_\tau = 6\pi i \int_{|s|=M_\tau^2} \frac{ds}{M_\tau^2} \left(1 - \frac{s}{M_\tau^2}\right)^2 \left[\left(1 + 2\frac{s}{M_\tau^2}\right) \Pi^{(1)}(s) + \Pi^{(0)}(s) \right]. \quad (2.5)$$

The naive prediction (1.2) for R_τ is reproduced by inserting into (2.5) the correlators for massless noninteracting quarks:

$$\Pi_{ij,V}^{(1)}(s) = \Pi_{ij,A}^{(1)}(s) = -\frac{N_c}{12\pi^2} \log(-s) + \text{constant}, \quad (2.6a)$$

$$\Pi_{ij,V}^{(0)}(s) = \Pi_{ij,A}^{(0)}(s) = 0. \quad (2.6b)$$

The advantage of the expression (2.5) for R_τ over (2.3) is that it requires the correlators only for complex s of order M_τ^2 , which is significantly larger than the scale associated with nonperturbative effects in QCD. The short distance OPE can therefore be used to organize both the perturbative and nonperturbative contributions to the correlators into a systematic expansion in powers of $1/s$. The possible uncertainties associated with the use of the OPE near the time-like axis are absent in this case because the integrand in (2.5) includes a factor $(1 - s/M_\tau^2)^2$, which provides a double zero at $s = M_\tau^2$, effectively suppressing the contribution from the region near the branch cut.

For scalar correlators, the operator product expansion takes the form [12]

$$\Pi^{(J)}(s) = \sum_{D=0,2,4,\dots} \frac{1}{(-s)^{D/2}} \sum_{\dim \mathcal{O}=D} \mathcal{C}^{(J)}(s, \mu) \langle \mathcal{O}(\mu) \rangle, \quad (2.7)$$

where the inner sum is over local gauge invariant scalar operators of dimension D . The parameter μ in (2.7) is an arbitrary factorization scale which separates long distance non-perturbative effects, which are absorbed into the vacuum matrix elements $\langle \mathcal{O}(\mu) \rangle$, from short distance effects which belong in the Wilson coefficients $\mathcal{C}^{(J)}(s, \mu)$. The only operator of dimension 0 is the unit operator. It is convenient to treat running quark masses $m_i(\mu)$ as operators, in which case the dimension-2 operators are of the form $m_i(\mu)m_j(\mu)$. The first dynamical operators appear at dimension 4 and are scale invariant; they are the quark condensates $\langle m_j \bar{\psi}_i \psi_i \rangle$ and the gluon condensate $\langle (\alpha_s/\pi)GG \rangle$. At dimension 6, there are dynamical operators with a nontrivial dependence on the scale μ . Since logarithms of light quark masses represent long distance kinematical effects, it is essential that all such logarithms be factorized into the matrix elements $\langle \mathcal{O}(\mu) \rangle$. The Wilson coefficients $\mathcal{C}^{(J)}(s, \mu)$ are then dimensionless functions of s and μ only. Since they represent short distance effects, they can be computed perturbatively as expansions in powers of $\alpha_s(\mu)$. For s on the contour $|s| = M_\tau^2$, large logarithms of the form $\log(-s/\mu^2)$ in the perturbation expansion of $\mathcal{C}^{(J)}(s, \mu)$ can be avoided by choosing the factorization scale to be $\mu = M_\tau$.

The current-current correlators defined in (2.1) should be smooth functions of q^μ as $q \rightarrow 0$. From the Lorentz decompositions (2.2), one can see that while $\Pi^{(0)}(q^2)$ and $\Pi^{(1)}(q^2)$ may both have poles at $q^2 = 0$, the combination $\Pi^{(0+1)}(q^2) \equiv \Pi^{(0)}(q^2) + \Pi^{(1)}(q^2)$ must have a smooth limit as $q \rightarrow 0$. It is then convenient to rewrite eq.(2.5) in the form

$$R_\tau = 6\pi i \int_{|s|=M_\tau^2} \frac{ds}{M_\tau^2} \left(1 - \frac{s}{M_\tau^2}\right)^2 \left[\left(1 + 2\frac{s}{M_\tau^2}\right) \Pi^{(0+1)}(s) - 2\frac{s}{M_\tau^2} \Pi^{(0)}(s) \right]. \quad (2.8)$$

If $\Pi^{(0)}(s)$ has a pole at $s = 0$, it cancels in $\Pi^{(0+1)}(s)$ and it contributes a constant to the $s\Pi^{(0)}(s)$ term, which integrates to 0 by Cauchy's residue theorem. Whether or not there is a pole at $q^2 = 0$ is a nonperturbative question involving long distance physics. From our understanding of the nonperturbative behavior of QCD, we know that the vector correlators $\Pi_{ij,V}^{(J)}(s)$ have no poles near $s = 0$. The axial vector correlator $\Pi_{ud,A}^{(J)}(s)$ has a pole at $s = m_\pi^2$, where m_π is the mass of the pion. In the chiral limit $m_u, m_d \rightarrow 0$, the pole approaches $s = 0$ and the pion becomes a Goldstone boson. The Goldstone nature of the pion makes it impossible to separate the transverse and longitudinal components of the axial two-point function in the OPE; this does not affect, however, the calculation of R_τ , since only the combinations $\Pi_{ud,A}^{(0+1)}$ and $s\Pi_{ud,A}^{(0)}$ are needed to compute the r.h.s. of eq. (2.8), and these can be unambiguously calculated using the OPE.

The dependence of the correlator (2.7) on the complex variable s resides in the powers $(-s)^{-D/2}$ and in the Wilson coefficients $\mathcal{C}^{(J)}(s, \mu)$, which have a weaker logarithmic dependence on s . After inserting the functions (2.7) into (2.8) and evaluating the contour

integral, the result can be expressed as an expansion in powers of $1/M_\tau^2$, with coefficients that depend only logarithmically on M_τ . It is convenient to express the corrections to R_τ from dimension D operators in terms of the fractional corrections $\delta_{ij,V/A}^{(D)}$ to the naive contribution from the current with quantum numbers ij, V or ij, A :

$$\delta_{ij,V/A}^{(D)} = \sum_{\dim \mathcal{O}=D} \frac{\langle \mathcal{O}(\mu) \rangle}{M_\tau^D} 4\pi i \int_{|s|=M_\tau^2} \frac{ds}{M_\tau^2} \left(\frac{-s}{M_\tau^2} \right)^{-D/2} \left(1 - \frac{s}{M_\tau^2} \right)^2 \left[\left(1 + 2 \frac{s}{M_\tau^2} \right) \mathcal{C}_{ij,V/A}^{(0+1)}(s, \mu) - 2 \frac{s}{M_\tau^2} \mathcal{C}_{ij,V/A}^{(0)}(s, \mu) \right], \quad (2.9)$$

where $\mathcal{C}_{ij,V/A}^{(J)}(s, \mu)$ are the Wilson coefficients for the correlators $\Pi_{ij,V/A}^{(J)}(s)$. The contour integral in (2.9) is dimensionless and depends only on the scales μ and M_τ . Setting $\mu = M_\tau$, the contour integral can be expressed as a function of the running coupling constant $\alpha_s(M_\tau)$ only.

The QCD calculation of R_τ has been criticized on the grounds that the operator product expansion can not reproduce with sufficient accuracy the effects of hadronic thresholds and resonances to allow any precise predictions [13]. This claim was based on calculations using models of hadrons that were incompatible with some of the fundamental aspects of QCD, such as chiral symmetry or the operator product expansion. R_τ depends only on the integrated hadronic spectrum, and not on the detailed structure of the hadronic spectral functions. Using the OPE, the integral (2.5) can be accurately calculated within QCD. This prediction gives in fact a consistency constraint that any model of hadrons should satisfy in order to be in agreement with QCD.

In terms of the fractional corrections defined in (2.9), the three experimentally measurable components of R_τ defined in (1.6) become

$$R_{\tau,V} = \frac{3}{2} |V_{ud}|^2 \left(1 + \delta^{(0)} + \sum_{D=2,4,\dots} \delta_{ud,V}^{(D)} \right), \quad (2.10a)$$

$$R_{\tau,A} = \frac{3}{2} |V_{ud}|^2 \left(1 + \delta^{(0)} + \sum_{D=2,4,\dots} \delta_{ud,A}^{(D)} \right), \quad (2.10b)$$

$$R_{\tau,S} = 3 |V_{us}|^2 \left(1 + \delta^{(0)} + \sum_{D=2,4,\dots} \delta_{us}^{(D)} \right), \quad (2.10c)$$

where $\delta_{ij}^{(D)}$ is the average of the vector (V) and axial vector (A) corrections: $\delta_{ij}^{(D)} = (\delta_{ij,V}^{(D)} + \delta_{ij,A}^{(D)})/2$. The dimension-0 correction $\delta^{(0)}$ is the purely perturbative correction neglecting quark masses, which is the same for all the components of R_τ : $\delta_{ij,V/A}^{(0)} = \delta^{(0)}$. Adding the three terms in (2.10), the total ratio R_τ is

$$R_\tau = 3 (|V_{ud}|^2 + |V_{us}|^2) \left(1 + \delta^{(0)} + \sum_{D=2,4,\dots} \left(\cos^2 \theta_C \delta_{ud}^{(D)} + \sin^2 \theta_C \delta_{us}^{(D)} \right) \right), \quad (2.11)$$

where the Cabbibo angle θ_C is defined by $\sin^2 \theta_C = |V_{us}|^2 / (|V_{ud}|^2 + |V_{us}|^2)$.

It is instructive to consider the form that the power corrections would take if the logarithmic dependence of the Wilson coefficients $\mathcal{C}^{(J)}(s, \mu)$ on s is neglected. In this case, the contour integrals in (2.9) can be evaluated trivially using Cauchy's residue theorem, and are nonzero only for $D = 2, 4, 6,$ and 8 . The corrections simplify even further if we also take the chiral limit $m_u, m_d, m_s \rightarrow 0$. The dimension-2 corrections then vanish because there are no operators of dimension 2. In the chiral limit, both the vector and axial vector currents are conserved, which implies $s\Pi_{ij,V}^{(J=0)}(s) = s\Pi_{ij,A}^{(J=0)}(s) = 0$. Thus only the $\Pi^{(0+1)}(s)$ term in (2.8) contributes to R_τ . The form of the kinematical factor multiplying $\Pi^{(0+1)}(s)$ in eq. (2.8) is such that when the s -dependence of the Wilson coefficients is ignored, only the $D = 6$ and $D = 8$ contributions survive the integration. The power corrections to R_τ in (2.10) then reduce to [2-4]

$$\delta_{ij,V/A}^{(D=4)} \simeq 0, \quad (2.12a)$$

$$\delta_{ij,V/A}^{(D=6)} \simeq -24\pi^2 \frac{\left[\sum \mathcal{C}_{ij,V/A}^{(0+1)} \langle \mathcal{O} \rangle \right]^{(D=6)}}{M_\tau^6}, \quad (2.12b)$$

$$\delta_{ij,V/A}^{(D=8)} \simeq -16\pi^2 \frac{\left[\sum \mathcal{C}_{ij,V/A}^{(0+1)} \langle \mathcal{O} \rangle \right]^{(D=8)}}{M_\tau^8}, \quad (2.12c)$$

$$\delta_{ij,V/A}^{(D=2n)} \simeq 0 \quad (\text{for } n \geq 5). \quad (2.12d)$$

When the logarithmic dependence of the Wilson coefficients on s is taken into account, operators of dimensions other than 6 and 8 do contribute, but they are suppressed by one or more powers of $\alpha_s(M_\tau)$. The largest power corrections to R_τ come from dimension 6 operators, which have no such suppression. We shall show in Section 5 that the power corrections to R_τ are numerically very small, and this is due in large part to the fact that the most important such correction falls off like the sixth power of $1/M_\tau$.

3. QCD CORRECTIONS

3.1. Perturbative Corrections

We shall find in Section 5 that the dimension 0 QCD correction to R_τ is by far the most significant numerically. It can be obtained by calculating the inclusive decay rate of the τ^- into ν_τ plus gluons and massless quarks using perturbative QCD, ignoring all the nonperturbative complications of the strong interactions. The formalism of the OPE in Section 2 is required only to justify the leading role of the perturbative QCD result, and to estimate the magnitude of the nonperturbative corrections.

The perturbative QCD contribution to R_τ can be expressed as a power series in $\alpha_s(M_\tau)$ and it is known to order $\alpha_s(M_\tau)^3$. It can be extracted from a recent calculation

to third order in α_s of the analogous ratio $R_{e^+e^-}(s)$ for e^+e^- annihilation:

$$R_{e^+e^-}(s) \equiv \frac{\sigma(e^+e^- \rightarrow \text{hadrons}(\gamma))}{\sigma(e^+e^- \rightarrow \mu^+\mu^-(\gamma))} = 12\pi \text{Im}\Pi_{em}(s+i\epsilon), \quad (3.1)$$

where $\Pi_{em}(s)$ is the correlator associated with the conserved electromagnetic current $J_{em}^\mu \equiv \sum_i Q_i \bar{\psi}_i \gamma^\mu \psi_i$ ($i = u, d, s, c, \dots$). As in the case of R_τ , the OPE can be used to expand $R(s)$ in powers of $1/s$ with all long distance nonperturbative effects factorized into vacuum matrix elements $\langle \mathcal{O}(\mu) \rangle$. The magnitude of these power corrections falls rapidly with s , and they are completely negligible for \sqrt{s} beyond a few GeV. Thus at high energy and far from quark thresholds, $R(s)$ is given to great accuracy by the perturbative contribution alone:

$$R_{e^+e^-}^{pert}(s) = 3 \left(\sum_i Q_i^2 \right) \left[1 + \frac{\alpha_s(\sqrt{s})}{\pi} + F_3 \left(\frac{\alpha_s(\sqrt{s})}{\pi} \right)^2 + F_4 \left(\frac{\alpha_s(\sqrt{s})}{\pi} \right)^3 \right] \\ + \left(\sum_i Q_i \right)^2 \left[F_4' \left(\frac{\alpha_s(\sqrt{s})}{\pi} \right)^3 \right], \quad (3.2)$$

where the error is of order $\alpha_s(\sqrt{s})^4$. Here, $\alpha_s(\sqrt{s})$ denotes the strong running coupling constant defined by the modified minimal subtraction renormalization scheme (\overline{MS}) and evaluated at the scale s . The $O(\alpha_s^2)$ coefficient was calculated more than a decade ago [14]: $F_3 = 1.9857 - 0.1153n_f$, where n_f denotes the number of quark flavours. A calculation of the $O(\alpha_s^3)$ correction was reported in ref. [15], where a very large value of F_4 was found ($F_4 = 67.340$ for $n_f = 3$). This could cast doubts on the usefulness of a perturbative expansion in powers of α_s . However, some errors were discovered [16] in a computer program used in this calculation. The four-loop corrections to $R(s)$ have been re-evaluated recently by two different groups, with the result [17,18]

$$F_4 = -6.6368 - 1.2001n_f - 0.0052n_f^2. \quad (3.3)$$

The new value ($F_4 = -10.284$ for $n_f = 3$) is smaller by almost an order of magnitude and has the opposite sign from the one given in ref. [15].

To calculate the perturbative QCD corrections to R_τ , we need the perturbative corrections for the combinations of correlators in (2.4). We are neglecting quark masses, so both the vector and axial vector currents are conserved. This implies $s\Pi^{(0)}(s) = 0$ and therefore only the correlator $\Pi^{(0+1)}(s)$ contributes to (2.8). Moreover, for massless quarks, the perturbative corrections to the spectral functions $\text{Im}\Pi_{ij,V/A}^{(0+1)}(s)$ are identical to the corrections to the $\sum_i Q_i^2$ term in (3.2). That these corrections are identical for vector (V) and axial vector (A) correlators is a consequence of the chiral invariance of the QCD interaction [19]. The term proportional to $(\sum_i Q_i)^2$ in (3.2) results from diagrams in which a separate quark loop is attached to each current. It contributes only to flavour

singlet correlators, and thus does not contribute to R_τ . The perturbative expression for the total spectral function for τ decay to order $\alpha(\sqrt{s})^3$ is then given by

$$\text{Im}\Pi^{(0+1)}(s+i\epsilon) = \frac{1}{2\pi} (|V_{ud}|^2 + |V_{us}|^2) \left[1 + \frac{\alpha_s(\sqrt{s})}{\pi} + F_3 \left(\frac{\alpha_s(\sqrt{s})}{\pi} \right)^2 + F_4 \left(\frac{\alpha_s(\sqrt{s})}{\pi} \right)^3 \right]. \quad (3.4)$$

In spite of the fact that the perturbative expression (3.4) is a poor approximation to the hadronic spectral function over most of the range $0 < s < M_\tau^2$, it can be used to calculate R_τ by inserting it for $\text{Im}\Pi^{(1)}(s+i\epsilon)$ in the integral (2.3). The reason is that the contour integral arguments of Section 2 guarantee that the dimension 0 contribution to R_τ can be expressed as a power series in $\alpha_s(M_\tau)$. While it is not an accurate representation of the spectral function, the perturbative expression (3.4) does give the correct coefficients in this expansion. The coupling constants $\alpha_s(\sqrt{s})$ in (3.4) can be expanded in powers of $\alpha_s(M_\tau)$, with coefficients that are polynomials in $\log(s/M_\tau^2)$:

$$\begin{aligned} \frac{\alpha_s(\sqrt{s})}{\pi} &= \frac{\alpha_s(M_\tau)}{\pi} + \frac{1}{2}\beta_1 \log \frac{s}{M_\tau^2} \left(\frac{\alpha_s(M_\tau)}{\pi} \right)^2 \\ &+ \left(\frac{1}{2}\beta_2 \log \frac{s}{M_\tau^2} + \frac{1}{4}\beta_1^2 \log^2 \frac{s}{M_\tau^2} \right) \left(\frac{\alpha_s(M_\tau)}{\pi} \right)^3 + \dots, \end{aligned} \quad (3.5)$$

where $\beta_1 = (2n_f - 33)/6$ and $\beta_2 = (19n_f - 153)/12$ are the first two coefficients of the QCD β -function. The integrals over s are then all elementary, and the result is [3–5]

$$\begin{aligned} R_\tau^{\text{pert}} &= 3 (|V_{ud}|^2 + |V_{us}|^2) \left[1 + \frac{\alpha_s(M_\tau)}{\pi} + \left(F_3 - \frac{19}{24}\beta_1 \right) \left(\frac{\alpha_s(M_\tau)}{\pi} \right)^2 \right. \\ &\left. + \left(F_4 - \frac{19}{12}F_3\beta_1 - \frac{19}{24}\beta_2 + \frac{265}{288}\beta_1^2 \right) \left(\frac{\alpha_s(M_\tau)}{\pi} \right)^3 \right]. \end{aligned} \quad (3.6)$$

We stress that the use of the perturbative expression (3.4) in the integral (2.3) is just a convenient shortcut for getting the expansion of R_τ in powers of $\alpha_s(M_\tau)$. A rigorous derivation of the result (3.6) is given in Appendix A. It makes use of the contour integral formula (2.8) and requires the knowledge of the correlators $\Pi^{(J)}(s)$ only on the contour $|s| = M_\tau^2$ where perturbation theory is valid.

A contour integral expression that reproduces the first two correction terms in (3.6) was first given in [2]. The complete result (3.6) was expressed as an expansion in powers of $1/\log(M_\tau/\Lambda_{\overline{MS}})$ in ref. [4], where it was pointed out that the sensitivity of R_τ to $\Lambda_{\overline{MS}}$ could be used to measure the fundamental QCD scale. This result was first expressed compactly as a power series in $\alpha_s(M_\tau)$ in ref. [5].

Setting the number of flavors n_f equal to 3 in (3.6), the fractional correction to the naive prediction (1.2) for R_τ is

$$\delta^{(D=0)} = \frac{\alpha_s(M_\tau)}{\pi} + 5.2023 \left(\frac{\alpha_s(M_\tau)}{\pi} \right)^2 + 26.366 \left(\frac{\alpha_s(M_\tau)}{\pi} \right)^3, \quad (3.7)$$

with an error of order $\alpha_s(M_\tau)^4$. The coefficient of $(\alpha_s(M_\tau)/\pi)^3$ is smaller by a factor of 4 than the coefficient that followed from the erroneous calculation of ref. [15].

3.2. Leading Quark Mass Corrections

The $1/M_\tau^2$ contributions $\delta^{(D=2)}$ to the ratio R_τ are simply the leading quark mass corrections to the perturbative QCD result of section 3.1. While corrections proportional to $m_i m_j$ are certainly tiny for the up and down quarks, the correction from the strange quark mass may not be negligible for strange decays. The leading quark mass corrections to the correlators (2.1) have been calculated to next-to-leading order in α_s in refs. [20], [21] and [22], and are given in Appendix A.2. Inserting these expressions into (2.8) and evaluating the contour integral, we find that the fractional corrections to R_τ defined in (2.9) are

$$\begin{aligned} \delta_{ij,V/A}^{(D=2)} = & -8 \left[1 + \frac{16}{3} \frac{\alpha_s(M_\tau)}{\pi} \right] \frac{m_i^2(M_\tau) + m_j^2(M_\tau)}{M_\tau^2} \\ & \pm 4 \left[1 + \frac{25}{3} \frac{\alpha_s(M_\tau)}{\pi} \right] \frac{m_i(M_\tau) m_j(M_\tau)}{M_\tau^2}, \end{aligned} \quad (3.8)$$

where $m_i(M_\tau)$ is the running mass of the quark of flavor i evaluated at the scale M_τ . The error in the coefficients are of order $\alpha_s(M_\tau)^2$. The average of the vector and axial vector contributions is

$$\delta_{ij}^{(D=2)} = -8 \left[1 + \frac{16}{3} \frac{\alpha_s(M_\tau)}{\pi} \right] \frac{m_i^2(M_\tau) + m_j^2(M_\tau)}{M_\tau^2}. \quad (3.9)$$

The leading quark mass correction was given in [2] in the form of a contour integral.

3.3. Dimension 4 Corrections

If the inclusive rate for τ^- to decay into gluons and massive quarks is calculated using perturbative QCD and expanded to fourth order in the quark masses m_i , the coefficients of the m^4 terms will contain logarithms of the quark masses. These logarithms are long distance kinematical effects of the quark masses. In the framework of the OPE described in section 2, they should be factorized into vacuum matrix elements of local operators $\langle \mathcal{O}(\mu) \rangle$ of dimension 4. As discussed in Appendix B, these operators can be constructed so that they are independent of the renormalization scale μ . The matrix elements of these renormalization-scale independent operators are called the gluon condensate $\langle (\alpha_s/\pi)GG \rangle$ and the quark condensates $\langle m_j \bar{\psi}_j \psi_j \rangle$. In addition to having small

perturbative contributions proportional to the fourth power of the light quark masses, the quark and gluon condensates also have large nonperturbative contributions. Besides these condensates, the only other dimension-4 operators are products of four running quark masses.

The dimension 4 terms in the OPE have been computed beyond leading order in refs. [22] and [23]. They are expressed in terms of the scale invariant quark and gluon condensates in appendix A.3. Inserting those expressions into the contour integral in (2.9), the fractional corrections to R_τ are found to be

$$\begin{aligned}
\delta_{ij,V/A}^{(D=4)} &= \frac{11}{4}\pi^2 \left(\frac{\alpha_s(M_\tau)}{\pi}\right)^2 \frac{\langle (\alpha_s/\pi)GG \rangle}{M_\tau^4} \\
&+ 16\pi^2 \left[1 + \frac{9}{2} \left(\frac{\alpha_s(M_\tau)}{\pi}\right)^2\right] \frac{\langle (m_i \mp m_j)(\bar{\psi}_i\psi_i \mp \bar{\psi}_j\psi_j) \rangle}{M_\tau^4} \\
&- 18\pi^2 \left(\frac{\alpha_s(M_\tau)}{\pi}\right)^2 \frac{\langle m_i\bar{\psi}_i\psi_i + m_j\bar{\psi}_j\psi_j \rangle}{M_\tau^4} \\
&- 8\pi^2 \left(\frac{\alpha_s(M_\tau)}{\pi}\right)^2 \sum_k \frac{\langle m_k\bar{\psi}_k\psi_k \rangle}{M_\tau^4} \\
&+ \left[-\frac{48}{7} \left(\frac{\alpha_s(M_\tau)}{\pi}\right)^{-1} + \frac{22}{7}\right] \frac{[m_i(M_\tau) \mp m_j(M_\tau)] [m_i^3(M_\tau) \mp m_j^3(M_\tau)]}{M_\tau^4} \\
&\pm 6 \frac{m_i(M_\tau)m_j(M_\tau)[m_i(M_\tau) \mp m_j(M_\tau)]^2}{M_\tau^4} + 36 \frac{m_i^2(M_\tau)m_j^2(M_\tau)}{M_\tau^4}.
\end{aligned} \tag{3.10}$$

The errors in the coefficients are of order $\alpha_s(M_\tau)^3$, $\alpha_s(M_\tau)^3$, and $\alpha_s(M_\tau)$ for the $\langle (\alpha_s/\pi)GG \rangle$, $\langle m\bar{\psi}\psi \rangle$, and m^4 terms, respectively. The inverse power of the coupling constant multiplying one of the m^4 terms arises from factorizing logarithms of a quark mass into the quark and gluon condensates [22]. The quark condensate contribution to leading order in α_s was given in [2]. A previous calculation [6] of the coefficient of the gluon condensate contained an algebraic error. Note that the gluon condensate is suppressed by two powers of $\alpha_s(M_\tau)/\pi$. This arises because the gluon condensate only contributes to the $\Pi^{(0+1)}$ correlator and the constant term in its Wilson coefficient gives a vanishing contribution to the contour integral (2.9). The first nonvanishing contribution comes from the variation in s of the order α_s term in the Wilson coefficient, and this is of order α_s^2 .

The average of the vector and axial-vector corrections is

$$\begin{aligned}
\delta_{ij}^{(D=4)} &= \frac{11}{4}\pi^2 \left(\frac{\alpha_s(M_\tau)}{\pi}\right)^2 \frac{\langle (\alpha_s/\pi)GG \rangle}{M_\tau^4} \\
&+ 16\pi^2 \left[1 + \frac{27}{8} \left(\frac{\alpha_s(M_\tau)}{\pi}\right)^2\right] \frac{\langle m_i\bar{\psi}_i\psi_i + m_j\bar{\psi}_j\psi_j \rangle}{M_\tau^4} \\
&- 8\pi^2 \left(\frac{\alpha_s(M_\tau)}{\pi}\right)^2 \sum_k \frac{\langle m_k\bar{\psi}_k\psi_k \rangle}{M_\tau^4} \\
&+ 24 \frac{m_i^2(M_\tau)m_j^2(M_\tau)}{M_\tau^4} \\
&+ \left[-\frac{48}{7} \left(\frac{\alpha_s(M_\tau)}{\pi}\right)^{-1} + \frac{22}{7}\right] \frac{m_i^4(M_\tau) + m_j^4(M_\tau)}{M_\tau^4}.
\end{aligned} \tag{3.11}$$

3.4. Dimension-6 corrections

The largest power corrections to the ratio R_τ come from the 4-quark operators of dimension 6. These operators have the form $(\bar{\psi}_i\Gamma\psi_j\bar{\psi}_k\Gamma\psi_l)(\mu)$, where Γ is the product of a Dirac matrix and an $SU(3)$ color matrix. The other dimension-6 operators are $G^3(\mu) \equiv f^{abc}G_\mu^{a\nu}G_\nu^{b\lambda}G_\lambda^{c\mu}$ plus lower dimension operators multiplied by running quark masses. The coefficient function of $G^3(\mu)$ vanishes to leading order in α_s [24], so we will neglect it. We also neglect all the dimension 6 operators that are suppressed by powers of the light quark masses.

The coefficient functions for the 4-quark operators have been calculated beyond leading order in ref. [25] and are given in Appendix A.4. After inserting them into the contour integral (2.9) and setting the renormalization scale to $\mu = M_\tau$, the fractional correction to

R_τ is

$$\begin{aligned}
& M_\tau^6 \delta_{ij,V/A}^{(D=6)} \\
&= 192\pi^4 \left[1 + \frac{485}{96} \frac{\alpha_s(M_\tau)}{\pi} \right] \frac{\alpha_s(M_\tau)}{\pi} \langle \bar{\psi}_i \gamma_\mu \begin{pmatrix} \gamma_5 \\ 1 \end{pmatrix} T^a \psi_j \bar{\psi}_j \gamma^\mu \begin{pmatrix} \gamma_5 \\ 1 \end{pmatrix} T^a \psi_i(M_\tau) \rangle \\
&\quad - 30\pi^4 \left(\frac{\alpha_s(M_\tau)}{\pi} \right)^2 \langle \bar{\psi}_i \gamma_\mu \begin{pmatrix} 1 \\ \gamma_5 \end{pmatrix} T^a \psi_j \bar{\psi}_j \gamma^\mu \begin{pmatrix} 1 \\ \gamma_5 \end{pmatrix} T^a \psi_i(M_\tau) \rangle \\
&\quad - 16\pi^4 \left(\frac{\alpha_s(M_\tau)}{\pi} \right)^2 \langle \bar{\psi}_i \gamma_\mu \begin{pmatrix} 1 \\ \gamma_5 \end{pmatrix} \psi_j \bar{\psi}_j \gamma^\mu \begin{pmatrix} 1 \\ \gamma_5 \end{pmatrix} \psi_i(M_\tau) \rangle \\
&\quad + \frac{64\pi^4}{3} \left[1 + \frac{26}{9} \frac{\alpha_s(M_\tau)}{\pi} \right] \frac{\alpha_s(M_\tau)}{\pi} \sum_k \langle (\bar{\psi}_i \gamma_\mu T^a \psi_i + \bar{\psi}_j \gamma_\mu T^a \psi_j) \bar{\psi}_k \gamma^\mu T^a \psi_k(M_\tau) \rangle \\
&\quad + \frac{200\pi^4}{9} \left(\frac{\alpha_s(M_\tau)}{\pi} \right)^2 \sum_k \langle (\bar{\psi}_i \gamma_\mu \gamma_5 T^a \psi_i + \bar{\psi}_j \gamma_\mu \gamma_5 T^a \psi_j) \bar{\psi}_k \gamma^\mu \gamma_5 T^a \psi_k(M_\tau) \rangle \\
&\quad + \frac{320\pi^4}{27} \left(\frac{\alpha_s(M_\tau)}{\pi} \right)^2 \sum_k \langle (\bar{\psi}_i \gamma_\mu \gamma_5 \psi_i + \bar{\psi}_j \gamma_\mu \gamma_5 \psi_j) \bar{\psi}_k \gamma^\mu \gamma_5 \psi_k(M_\tau) \rangle \\
&\quad + \frac{64\pi^4}{27} \left(\frac{\alpha_s(M_\tau)}{\pi} \right)^2 \sum_{k,l} \langle \bar{\psi}_k \gamma_\mu T^a \psi_k \bar{\psi}_l \gamma^\mu T^a \psi_l(M_\tau) \rangle .
\end{aligned} \tag{3.12}$$

The upper component of $\begin{pmatrix} 1 \\ \gamma_5 \end{pmatrix}$ or $\begin{pmatrix} \gamma_5 \\ 1 \end{pmatrix}$ is for the vector (V) correlator, while the lower component is for the axial vector (A).

The number of independent operators appearing in (3.12) is rather large. At present, we don't have precise phenomenological estimates of their matrix elements that can match the accurate calculations of their Wilson coefficients. The matrix elements of 4-quark operators have been traditionally simplified using the vacuum saturation approximation [12] to express them in terms of products of 2-quark matrix elements $\langle \bar{\psi}\psi(\mu) \rangle$. Unfortunately the vacuum saturation approximation is inconsistent with the scaling properties of the 4-quark operators [26], so the terms of order α_s^2 in the Wilson coefficients are meaningless within this approximation. Keeping only the terms of order α_s in the Wilson coefficients, the vacuum saturation approximation applied to (3.12) gives

$$\begin{aligned}
\delta_{ij,V/A}^{(D=6)} \simeq & \pm \frac{256\pi^4}{3} \frac{\alpha_s(\mu)}{\pi} \frac{\langle \bar{\psi}_i \psi_i(\mu) \rangle \langle \bar{\psi}_j \psi_j(\mu) \rangle}{M_\tau^6} \\
& - \frac{256\pi^4}{27} \frac{\alpha_s(\mu)}{\pi} \frac{\langle \bar{\psi}_i \psi_i(\mu) \rangle^2 + \langle \bar{\psi}_j \psi_j(\mu) \rangle^2}{M_\tau^6} .
\end{aligned} \tag{3.13}$$

The combination of operators $\alpha_s(\mu) \langle \bar{\psi}_i \psi_i(\mu) \rangle \langle \bar{\psi}_j \psi_j(\mu) \rangle$ is almost scale invariant: its anomalous dimension is $(\beta_1 + 2\gamma_1)\alpha_s/\pi$, which is fortuitously small for QCD with 3 flavors of quarks. Thus if the vacuum saturation approximation was a good one at some hadronic scale μ , it should remain a reasonable approximation at the scale M_τ .

Unfortunately, the vacuum saturation approximation is really just a simplifying assumption. There are no strong theoretical reasons to expect it to be a good approximation at any scale μ . In fact, it is well known [27–29] that the vacuum saturation approximation underestimates the $D = 6$ contributions to the OPE. One approach that has been used to take into account deviations from the vacuum saturation approximation is to replace $\alpha_s(\mu) \langle \bar{\psi}_i \psi_i(\mu) \rangle \langle \bar{\psi}_j \psi_j(\mu) \rangle$ in (3.13) by an effective scale invariant matrix element $\rho \alpha_s \langle \bar{\psi} \psi \rangle^2$ which is determined phenomenologically [27–29]. The approximation (3.13) is then replaced by

$$\delta_{ij,V/A}^{(D=6)} \simeq \begin{pmatrix} 7 \\ -11 \end{pmatrix} \frac{256\pi^3}{27} \frac{\rho \alpha_s \langle \bar{\psi} \psi \rangle^2}{M_\tau^6}. \quad (3.14)$$

When these contributions are averaged to give $\delta^{(D=6)}$, there is a large cancellation between the axial and vector contributions.

It is difficult to provide a reliable error estimate for the approximation (3.14), because there is no limit of QCD in which it becomes exact. As we will see in section 5, the uncertainty in the estimate (3.14) will be one of the main limitations to the accuracy of our predictions.

3.5. Dimension-8 and higher corrections

The contributions from higher dimension operators are expected to be quite small, since they are suppressed by additional powers of M_τ . For $D \geq 10$, the power corrections are further suppressed by one or more powers of $\alpha_s(M_\tau)$, as pointed out at the end of section 2. They can therefore be safely neglected.

The coefficient functions of $D = 8$ operators contributing to the vector correlation function (2.1a) have been computed in the chiral limit in ref. [30]. To our knowledge, the corresponding calculation for the axial-vector correlator (2.1b) has not yet been done. In order to have an order of magnitude estimate of the uncertainty associated with the $D = 8$ correction to R_τ , we will consider the effect of the purely gluonic operators, which should give the same contribution to the vector and axial-vector channels. Using the results given in appendix A.5, it is straightforward to obtain:

$$M_\tau^8 \delta_{ij,V/A}^{(D=8)} \approx \frac{1}{54} \langle 33 O_1 + 59 O_2 + 34 O_3 - 218 O_4 \rangle, \quad (3.15)$$

where the O_i ($i=1,\dots,4$) are G^4 operators, whose explicit form is given in eq. (A.15).

The vacuum expectation values of these G^4 operators are not well determined. Their size has been estimated in ref. [31] using heavy-quark expansion techniques together with quark-condensate factorization. Inserting these estimates in eq. (3.15), one gets

$$\delta_{ij,V/A}^{(D=8)} \approx -\frac{39}{162} \pi^2 \frac{\langle \frac{\alpha_s}{\pi} GG \rangle^2}{M_\tau^8} \sim -10^{-5}, \quad (3.16)$$

which is completely negligible. Even if one assigns to this estimate a generous error of about an order of magnitude ², the $D = 8$ correction is much smaller than the uncertainties associated with the lower dimension contributions to R_τ . Therefore we will neglect the $D = 8$ contribution in the numerical analysis to be presented in section 5.

4. ELECTROWEAK CORRECTIONS

The electroweak corrections to the ratio R_τ defined in (1.1) are surprisingly large, because the electroweak corrections to the numerator of (1.1) include logarithms of M_Z/M_τ , which are not present in the corrections to the denominator. The logarithms arise because the pure QED correction to the decay rate for $\tau^- \rightarrow \nu_\tau d\bar{u}$ or $\tau \rightarrow \nu_\tau s\bar{u}$ is ultraviolet divergent. There is no such divergence in the QED correction for the leptonic decay $\tau^- \rightarrow \nu_\tau e^- \bar{\nu}_e$, because the divergence cancels for the particular combination of electric charges of the particles in this reaction. In the Standard Model, the divergence in the correction to the decay rate into quarks is cut off at the weak scale, leaving a logarithm of M_Z . A complete calculation of the electroweak correction to order α has recently been carried out [32]. It can be expressed as a fractional correction δ_{EW} that should be added to the other fractional corrections in (2.11):

$$\delta_{EW} = \left(\frac{5}{12} + 2 \log \frac{M_Z}{M_\tau} \right) \frac{\alpha(M_\tau)}{\pi}. \quad (4.1)$$

The running coupling constant for QED at the scale M_τ is $\alpha(M_\tau) = 1/133.29$.

The logarithm in (4.1) was calculated previously [33]. It represents a short distance correction to the low energy effective four-fermion coupling of the τ to $\nu_\tau d\bar{u}$ or $\nu_\tau s\bar{u}$. The QCD corrections discussed in Section 3 will also be modified by this short distance correction. The logarithmic term in (4.1) should therefore be absorbed into an overall multiplicative correction S_{EW} to the formula (2.11). Including the electroweak correction, (2.11) should read

$$R_\tau = 3 (|V_{ud}|^2 + |V_{us}|^2) S_{EW} \left(1 + \delta'_{EW} + \delta^{(0)} + \sum_{D=2,4,\dots} \left(\cos^2 \theta_C \delta_{ud}^{(D)} + \sin^2 \theta_C \delta_{us}^{(D)} \right) \right). \quad (4.2)$$

The residual electroweak correction is $\delta'_{EW} = (5/12)\alpha(M_\tau)/\pi \simeq 0.0010$. To order α , the short distance factor is $S_{EW} = 1 + 2 \log(M_Z/M_\tau)\alpha(M_\tau)/\pi \simeq 1.0188$.

The renormalization group can be used to sum up higher order electroweak corrections of the form $\alpha^n \log^n(M_Z/M_\tau)$. Assuming that the top quark has a mass larger than M_Z , the short distance factor in (4.2) becomes [34]

$$S_{EW} = \left(\frac{\alpha(M_b)}{\alpha(M_\tau)} \right)^{9/19} \left(\frac{\alpha(M_W)}{\alpha(M_b)} \right)^{9/20} \left(\frac{\alpha(M_Z)}{\alpha(M_W)} \right)^{36/17}. \quad (4.3)$$

² A bigger value for the $D = 8$ correction to the correlators (2.1a, b) has in fact been obtained from a fit to τ -decay data [28,29].

The running QED coupling constants at the masses of the b -quark, W^\pm , and Z^0 are $\alpha(M_b) = 1/132.05$, $\alpha(M_W) = 1/127.97$, and $\alpha(M_Z) = 1/127.93$, respectively. The numerical value of the short distance factor in (4.3) is therefore $S_{EW} = 1.0194$. The effect of the summation of leading logarithms via the renormalization group is comparable to that of the residual electroweak correction δ'_{EW} in (4.2).

If the short distance factor (4.3) is used in (4.2), the remaining perturbative electroweak corrections are of order $\log(M_Z/M_\tau)\alpha(M_\tau)^2$ and are therefore negligible. There are also QCD corrections to the electroweak correction. While nonperturbative QCD effects significantly modify the spectrum of photons emitted in the semihadronic decay of the τ , their effect on the inclusive decay rate is probably very small. It should be possible to organize these corrections systematically into an expansion in powers of $1/M_\tau$, similar to that given in Section 3 for the pure QCD correction. All nonperturbative and other long distance effects would be factorized into hadronic matrix elements that would have to be determined phenomenologically. If this could be done, it would guarantee that these corrections would be suppressed relative to the pure QCD power corrections by the QED coupling constant $\alpha(M_\tau)$, in which case they would be completely negligible.

5. NUMERICAL ANALYSIS

In this section we present numerical estimates of all the contributions to R_τ .

The fractional perturbative QCD correction $\delta^{(D=0)}$ is given in Table 1 for different values of the running coupling constant $\alpha_s(M_\tau)$ or, equivalently, different values of the parameter $\Lambda_{\overline{MS}}$. Our definition of $\Lambda_{\overline{MS}}$ (see Appendix A) corresponds to $n_f = 3$, with the β -function evaluated at the three-loop level. The perturbative series (3.7) converges quite well; for instance, taking $\alpha_s(M_\tau) = 0.30$, the size of the $\alpha_s(M_\tau)$, $\alpha_s(M_\tau)^2$ and $\alpha_s(M_\tau)^3$ corrections is 9.5%, 4.7% and 2.3% respectively. We can estimate the error due to unknown higher order corrections by noting that the corrections of order $\alpha_s(M_\tau)^2$ and $\alpha_s(M_\tau)^3$ are both smaller than the previous term by a factor of about $5\alpha_s(M_\tau)/\pi$. It is reasonable to expect the $\alpha_s(M_\tau)^4$ term to be smaller by a similar factor. We therefore estimate the error in $\delta^{(D=0)}$ due to higher order perturbative corrections to be $\pm 130(\alpha_s(M_\tau)/\pi)^4$. In the case $\alpha_s(M_\tau) = 0.30$, this error is about 1%.

The uncertainty in $\delta^{(D=0)}$ due to renormalization scheme dependence has been analyzed in ref. [35]. The inclusion of the $O(\alpha_s^3)$ corrections considerably improves the agreement among the results obtained with different renormalization schemes. Note that our predictions in table 1 refer to a given value of $\alpha_s(M_\tau)$ in the \overline{MS} renormalization scheme. A change of renormalization scheme would modify both the values of the coefficients in eq. (3.7) and the numerical value of the coupling constant $\alpha_s(M_\tau)$. When both changes are taken into account, the error due to renormalization scheme dependence is of order $\alpha_s(M_\tau)^4$. This is not an independent source of error from the uncalculated order $\alpha_s(M_\tau)^4$ correction, and is adequately taken into account in our estimate $\pm 130(\alpha_s(M_\tau)/\pi)^4$ for the perturbative error. Also included in this error estimate is the ambiguity from the choice of

$\alpha_s(M_\tau)$	$\Lambda_{\overline{MS}}(MeV)$	$\delta^{(D=0)}$
0.16	52	0.0679 ± 0.0009
0.18	81	0.0793 ± 0.0014
0.20	114	0.0915 ± 0.0021
0.22	150	0.1046 ± 0.0031
0.24	189	0.1185 ± 0.0044
0.26	229	0.1333 ± 0.0061
0.28	269	0.1491 ± 0.0082
0.30	308	0.1659 ± 0.0108
0.32	347	0.1837 ± 0.0140
0.34	384	0.2026 ± 0.0178
0.36	420	0.2226 ± 0.0224
0.38	454	0.2437 ± 0.0278
0.40	487	0.2661 ± 0.0342
0.42	518	0.2897 ± 0.0415
0.44	547	0.3145 ± 0.0500

Table 1
Perturbative corrections

the scale μ in the expansion parameter $\alpha_s(\mu)$, which is just a special case of renormalization scheme dependence.

The perturbation expansions of $R_{e^+e^-}$ and R_τ are known to be at best asymptotic expansions [36–39] with coefficients F_n that eventually grow like $n!$ for large n . Asymptotically, the coefficients F_n are predicted to all have the same sign, making the series not Borel summable. One might worry that our estimate of the error in $\delta^{(D=0)}$ could be a severe underestimate if the asymptotic factorial growth has set in already at $n = 4$. Fortunately this possibility can be ruled out for R_τ . One can show that the asymptotic ratio of the coefficients F_{n+1}/F_n for $R_{e^+e^-}$ must be identical to that for R_τ . While the ratio F_4/F_3 in the expansion (3.2) for $R_{e^+e^-}$ is negative, the corresponding ratio for R_τ given in (3.7) is positive. We conclude that the asymptotic factorial growth of the perturbation expansion has not yet set in at $n = 4$ for R_τ . It is therefore reasonable to estimate the size of the

coefficient of $(\alpha_s(M_\tau)/\pi)^4$ by assuming only algebraic growth of the coefficients as we have done above.

Table 2 shows the leading ($D = 2$) corrections induced by the non-zero values of the light-quark masses. Since the coefficients of the m^2 contributions (3.8) are only known at $O(\alpha_s(M_\tau))$, we have used for consistency the running quark-masses at the two-loop level. For the renormalization-invariant quark mass parameters \hat{m}_i defined in Appendix A.5, we have taken the values [40,41]

$$\hat{m}_u = (8.7 \pm 1.5)MeV, \quad \hat{m}_d = (15.4 \pm 1.5)MeV, \quad \hat{m}_s = (270. \pm 30.)MeV. \quad (5.1)$$

The quark-mass corrections are negligible for nonstrange decays. They give a sizeable correction to the ratio $R_{\tau,S}$ for strange decays, which is approximately -15% for $\alpha_s(M_\tau) = 0.30$. Nevertheless, due to the $\sin^2 \theta_C$ suppression, the effect on the total ratio R_τ in (2.11) is only -0.7% .

In Table 3 we show the fractional corrections to R_τ induced by dimension-4 operators. For the gluon condensate, we have used the input value [40]

$$\langle \frac{\alpha_s}{\pi} GG \rangle = (0.02 \pm 0.01) GeV^4. \quad (5.2)$$

The quark condensates are conveniently parameterized by $\langle m_j \bar{\psi}\psi \rangle = -\hat{m}_j \hat{\mu}_j^3$, where \hat{m}_i are the quark mass parameters given in (5.1). For the parameters $\hat{\mu}_i$, we use the input values [40]

$$\hat{\mu}_u = \hat{\mu}_d = (189 \pm 7) MeV, \quad \hat{\mu}_s = (160 \pm 10) MeV. \quad (5.3)$$

The quoted error in Table 3 is mainly due to the uncertainty in the leading quark-condensate contribution (the second term on the r.h.s. of eq. (3.10)), except for $\delta_{ud,V}^{(D=4)}$ where the uncertainty in the value of the gluon condensate dominates. The large relative errors in $\delta_{us,V}^{(D=4)}$ are due to a numerical cancellation between the leading quark condensate and the mass term m_s^4 , which is enhanced by an inverse power of the coupling constant $\alpha_s(M_\tau)$. The $D = 4$ correction to the total ratio R_τ is very small, less than 0.7% for $\alpha_s(M_\tau) = 0.30$.

The biggest nonperturbative QCD corrections to R_τ come from the dimension-6 condensates. At present, our best estimate of these contributions comes from eq. (3.14), using the input value

$$\rho \alpha_s \langle \bar{\psi}\psi \rangle^2 \approx (3.8 \pm 2.0) \times 10^{-4} GeV^6 \quad (5.4)$$

which is obtained from phenomenological fits to different sets of data [27–29]. The resulting predictions for the fractional corrections of dimension 6 are

$$\begin{aligned} \delta_{ij,V}^{(D=6)} &\approx (2.4 \pm 1.3) \times 10^{-2}, \\ \delta_{ij,A}^{(D=6)} &\approx -(3.8 \pm 2.0) \times 10^{-2}, \\ \delta_{ij}^{(D=6)} &\approx -(0.7 \pm 0.4) \times 10^{-2}. \end{aligned} \quad (5.5)$$

$\alpha_s(M_\tau)$	$\delta_{ud,V}^{(D=2)} \times 10^3$	$\delta_{ud,A}^{(D=2)} \times 10^3$	$\delta_{us,V}^{(D=2)}$	$\delta_{us,A}^{(D=2)}$
0.16	-0.22 ± 0.05	-0.37 ± 0.05	-0.068 ± 0.015	-0.070 ± 0.015
0.18	-0.26 ± 0.06	-0.42 ± 0.06	-0.078 ± 0.018	-0.081 ± 0.018
0.20	-0.29 ± 0.07	-0.48 ± 0.07	-0.089 ± 0.020	-0.092 ± 0.020
0.22	-0.33 ± 0.08	-0.54 ± 0.08	-0.100 ± 0.023	-0.104 ± 0.023
0.24	-0.37 ± 0.09	-0.61 ± 0.09	-0.112 ± 0.025	-0.116 ± 0.025
0.26	-0.41 ± 0.10	-0.68 ± 0.10	-0.124 ± 0.028	-0.129 ± 0.028
0.28	-0.45 ± 0.11	-0.75 ± 0.11	-0.137 ± 0.031	-0.143 ± 0.031
0.30	-0.49 ± 0.12	-0.83 ± 0.12	-0.151 ± 0.034	-0.157 ± 0.034
0.32	-0.54 ± 0.13	-0.91 ± 0.13	-0.165 ± 0.037	-0.172 ± 0.037
0.34	-0.58 ± 0.14	-0.99 ± 0.14	-0.180 ± 0.041	-0.187 ± 0.041
0.36	-0.63 ± 0.15	-1.08 ± 0.15	-0.196 ± 0.044	-0.203 ± 0.044
0.38	-0.68 ± 0.16	-1.17 ± 0.16	-0.212 ± 0.048	-0.220 ± 0.048
0.40	-0.74 ± 0.18	-1.26 ± 0.18	-0.228 ± 0.052	-0.238 ± 0.052
0.42	-0.79 ± 0.19	-1.36 ± 0.19	-0.246 ± 0.056	-0.256 ± 0.056
0.44	-0.85 ± 0.20	-1.46 ± 0.20	-0.264 ± 0.060	-0.275 ± 0.060

Table 2

Leading quark-mass corrections

The uncertainty in $\delta_{ij,V/A}^{(D=6)}$ is a big limitation to the accuracy of our predictions for the separate vector and axial-vector contributions to R_τ . Note however that the absolute error in the sum $\delta_{ij}^{(D=6)}$ of the vector and axial vector corrections is much smaller due to the cancellation in (3.13) of the operator with the largest Wilson coefficient.

The electroweak corrections are given in (4.2) and include the additive fractional correction $\delta'_{EW} = 0.0010$ and the overall multiplicative short distance factor $S_{EW} = 1.0194$. Our final predictions for $R_{\tau,V}$, $R_{\tau,A}$, $R_{\tau,S}$ and R_τ , including the electroweak corrections, are given in Table 4. For the Cabibbo-Kobayashi-Maskawa mixing factors we have used the values [42]

$$V_{ud} = 0.9753 \pm 0.0006 \quad ; \quad V_{us} = 0.221 \pm 0.003, \quad (5.6)$$

which were determined under the assumption that the 3 by 3 mixing matrix V_{ij} is unitary.

$\alpha_s(M_\tau)$	$\delta_{ud,V}^{(D=4)} \times 10^3$	$\delta_{ud,A}^{(D=4)} \times 10^3$	$\delta_{us,V}^{(D=4)}$	$\delta_{us,A}^{(D=4)}$
0.16	0.17 ± 0.07	-5.0 ± 0.6	0.005 ± 0.005	-0.054 ± 0.007
0.18	0.22 ± 0.09	-4.9 ± 0.6	0.005 ± 0.005	-0.054 ± 0.007
0.20	0.27 ± 0.11	-4.9 ± 0.6	0.004 ± 0.005	-0.055 ± 0.007
0.22	0.33 ± 0.13	-4.9 ± 0.6	0.004 ± 0.005	-0.056 ± 0.007
0.24	0.39 ± 0.16	-4.8 ± 0.6	0.003 ± 0.005	-0.057 ± 0.007
0.26	0.45 ± 0.18	-4.8 ± 0.6	0.002 ± 0.005	-0.058 ± 0.007
0.28	0.53 ± 0.21	-4.7 ± 0.7	0.002 ± 0.005	-0.059 ± 0.007
0.30	0.60 ± 0.24	-4.7 ± 0.7	0.001 ± 0.005	-0.060 ± 0.007
0.32	0.69 ± 0.28	-4.6 ± 0.7	0.001 ± 0.005	-0.061 ± 0.007
0.34	0.78 ± 0.31	-4.6 ± 0.7	0.000 ± 0.005	-0.062 ± 0.007
0.36	0.87 ± 0.35	-4.5 ± 0.7	0.000 ± 0.005	-0.063 ± 0.007
0.38	0.97 ± 0.39	-4.4 ± 0.7	-0.001 ± 0.005	-0.064 ± 0.008
0.40	1.08 ± 0.44	-4.4 ± 0.8	-0.002 ± 0.005	-0.065 ± 0.008
0.42	1.19 ± 0.48	-4.3 ± 0.8	-0.002 ± 0.005	-0.066 ± 0.008
0.44	1.30 ± 0.53	-4.2 ± 0.8	-0.003 ± 0.005	-0.067 ± 0.008

Table 3

Fractional corrections induced by dimension-4 operators.

The errors given in Table 4 are obtained by adding in quadrature the errors from the uncalculated order- α_s^4 correction and the errors from the input values in (5.1), (5.2), (5.3), (5.4), and (5.6). For $R_{\tau,V}$, $R_{\tau,A}$ and R_τ , the only significant sources of error are the higher order corrections to $\delta^{(D=0)}$, which we have estimated to be $\pm 130(\alpha_s(M_\tau)/\pi)^4$, and the dimension-6 operator given in (5.4). The strange quark mass \hat{m}_s also gives a significant contribution to the error in $R_{\tau,S}$.

6. CONCLUSIONS

We have presented an updated calculation of the ratio R_τ for τ decay, including all available perturbative and nonperturbative contributions. We have decomposed our predictions into vector (V), axial vector (A), and strange (S) components. Our final results

$\alpha_s(M_\tau)$	$R_{\tau,V}$	$R_{\tau,A}$	$R_{\tau,S}$	R_τ
0.16	1.59 ± 0.02	1.49 ± 0.03	0.145 ± 0.004	3.23 ± 0.01
0.18	1.61 ± 0.02	1.51 ± 0.03	0.145 ± 0.004	3.26 ± 0.01
0.20	1.62 ± 0.02	1.53 ± 0.03	0.145 ± 0.005	3.29 ± 0.02
0.22	1.64 ± 0.02	1.55 ± 0.03	0.145 ± 0.005	3.33 ± 0.02
0.24	1.66 ± 0.02	1.57 ± 0.03	0.145 ± 0.005	3.37 ± 0.02
0.26	1.68 ± 0.02	1.59 ± 0.03	0.145 ± 0.005	3.42 ± 0.02
0.28	1.71 ± 0.02	1.61 ± 0.03	0.146 ± 0.005	3.46 ± 0.03
0.30	1.73 ± 0.02	1.63 ± 0.03	0.146 ± 0.006	3.51 ± 0.04
0.32	1.76 ± 0.03	1.66 ± 0.04	0.146 ± 0.006	3.56 ± 0.05
0.34	1.79 ± 0.03	1.69 ± 0.04	0.147 ± 0.007	3.62 ± 0.06
0.36	1.81 ± 0.04	1.72 ± 0.04	0.147 ± 0.007	3.68 ± 0.07
0.38	1.85 ± 0.04	1.75 ± 0.05	0.148 ± 0.008	3.74 ± 0.09
0.40	1.88 ± 0.05	1.78 ± 0.06	0.148 ± 0.009	3.81 ± 0.11
0.42	1.91 ± 0.06	1.81 ± 0.07	0.149 ± 0.010	3.88 ± 0.13
0.44	1.95 ± 0.08	1.85 ± 0.08	0.150 ± 0.011	3.95 ± 0.15

Table 4

Final predictions for the different components of the τ hadronic width.

for R_τ as a function of the coupling constant $\alpha_s(M_\tau)$ are given in the final column of Table 4. The quoted error is mainly due to the uncalculated perturbative QCD correction of order $\alpha_s(M_\tau)^4$, which we have estimated to be $\pm 130(\frac{\alpha_s(M_\tau)}{\pi})^4$, and to the estimated $1/M_\tau^6$ power correction due to nonperturbative QCD effects, which has been estimated using information from QCD sum rules. These are the only significant sources of uncertainty in the calculation of R_τ .

One application of these calculations is the determination of the QCD coupling constant at the scale M_τ . The decay of the τ is the lowest energy process from which one can extract a value of α_s without hopeless complications from nonperturbative effects. Using Table 4, experimental measurements of the ratio R_τ can be translated into values of $\alpha_s(M_\tau)$. There are two completely independent methods for measuring R_τ experi-

mentally. The value obtained from the leptonic branching fractions B_e and B_μ of the τ is given in (1.5a). From Table 4, the corresponding value for the QCD coupling is $\alpha_s(M_\tau) = 0.36 \pm 0.04$. Using the value (1.5b) determined from the τ lifetime, one obtains $\alpha_s(M_\tau) = 0.21 \pm 0.07$. The discrepancy between these two determinations of α_s reflects the 2 standard deviation discrepancy between the two independent determinations of R_τ . Both the leptonic branching fractions and the lifetime of the τ will be measured with great accuracy in the near future. The error in the determination of $\alpha_s(M_\tau)$ will then be dominated by the uncertainty in our calculation, and this will allow a determination of $\alpha_s(M_\tau)$ to about 10%.

Once the running coupling constant $\alpha_s(\mu)$ is determined at the scale M_τ , it can be evolved to higher energies using the renormalization group. The error bar on $\alpha_s(\mu)$ must also be evolved using the renormalization group. Its size scales roughly as $\alpha_s(\mu)^2$, and it therefore shrinks as μ increases. Thus a modest precision in the determination of α_s at low energies results in a very high precision in the coupling constant at high energies.

The formal average of $R_\tau^{exp,B}$ and $R_\tau^{exp,\Gamma}$, $R_\tau^{exp} = 3.61 \pm 0.05$, corresponds to $\alpha_s(M_\tau) = 0.34 \pm 0.04$. After evolution up to the scale $M_Z = 91.2 GeV$, this running coupling constant decreases to $\alpha_s(M_Z) = 0.120_{-0.005}^{+0.004}$, in amazing agreement with the present LEP average [43], $\alpha_s(M_Z) = 0.120 \pm 0.007$, and with a smaller error bar. The comparison of these two determinations of $\alpha_s(\mu)$ in two extreme energy regimes, M_τ and M_Z , provides a beautiful test of the predicted running of the QCD coupling constant.

Reversing this logic, a precise determination of $\alpha_s(\mu)$ at high energies can be used to predict the ratio R_τ . Using the renormalization group to evolve down the LEP value $\alpha_s(M_Z) = 0.120 \pm 0.007$, one gets $\alpha_s(M_\tau) = 0.34_{-0.06}^{+0.08}$. Our calculations imply then $R_\tau = 3.6_{-0.2}^{+0.4}$. The central value is very close to the experimental result (1.5a) obtained by measuring the leptonic branching fractions. However, the big error bar makes this result also compatible with the value (1.5b) extracted from the measured τ -lifetime.

Further accumulation of data from LEP will result in a still more precise measurement of $\alpha_s(M_Z)$, allowing an even sharper prediction for R_τ . It is only a matter of time before the present discrepancy between the experimental values of R_τ is resolved by precise measurements of the τ lifetime or its leptonic branching fractions. Agreement with the theoretical predictions for R_τ would be a spectacular triumph for QCD.

Acknowledgements

We have benefitted from discussions with D. Broadhurst, M. Davier, J. Ellis, T. Hebbeker, W. Marciano, M. Martinez and H. Wachsmuth. We are especially grateful to F. Le Diberder for checking some of our final numerics. S.N. would like to thank the hospitality of the CERN Theory Division, where part of this work has been done. The work of E.B. has been supported in part by the Department of Energy, U. S. A., under contract No. DE-AC02-76-ER022789. The work of A.P. has been supported in part by CICYT, Spain, under grant No. AEN90-0040.

Appendix A. COMPENDIUM OF COEFFICIENT FUNCTIONS

The coefficient functions for the operator product expansion (OPE) of current-current correlators were first calculated at leading order by Shifman, Vainshtein, and Zakharov [12]. Calculations of the coefficient functions beyond leading order are scattered throughout the literature. In this appendix, we collect the coefficient functions that are used in the calculation of R_τ .

The general form for the OPE of scalar correlators is given in (2.7). At Euclidean values $s \equiv -Q^2$ of the hadronic invariant mass, the dimension- D contribution to the scalar correlators associated with the ij, V or ij, A current is

$$\left[\Pi_{ij, V/A}^{(J)}(-Q^2) \right]^{(D)} = \frac{1}{Q^D} \sum_{\dim \mathcal{O}=D} c_{ij, V/A}^{(J)}(-Q^2, \mu) \langle \mathcal{O}(\mu) \rangle. \quad (\text{A.1})$$

The correlators compiled in this appendix have been calculated consistently using dimensional regularization to regularize ultraviolet divergences and the modified minimal subtraction renormalization scheme (\overline{MS}) to remove the divergences. Thus the running coupling constants $\alpha_s(\mu)$ and running masses $m_i(\mu)$ are those of the \overline{MS} scheme. The running coupling constant can be parameterized as follows:

$$\begin{aligned} \frac{\alpha_s(\mu)}{\pi} = a_s \left\{ 1 - a_s \frac{\beta_2}{\beta_1} \log \left(\log \frac{\mu^2}{\Lambda_{\overline{MS}}^2} \right) \right. \\ \left. + a_s^2 \left[\frac{\beta_2^2}{\beta_1^2} \log^2 \left(\log \frac{\mu^2}{\Lambda_{\overline{MS}}^2} \right) - \frac{\beta_2^2}{\beta_1^2} \log \left(\log \frac{\mu^2}{\Lambda_{\overline{MS}}^2} \right) - \frac{\beta_2^2}{\beta_1^2} + \frac{\beta_3}{\beta_1} \right] + O(a_s^3) \right\}, \end{aligned} \quad (\text{A.2})$$

where

$$a_s \equiv \frac{1}{-\beta_1 \log(\mu/\Lambda_{\overline{MS}})}, \quad (\text{A.3})$$

and β_i are the $O(\alpha_s^i)$ coefficients of the QCD β -function [44] :

$$\begin{aligned} \beta_1 &= -\frac{11}{2} + \frac{n_f}{3}, \\ \beta_2 &= -\frac{51}{4} + \frac{19}{12}n_f, \\ \beta_3 &= \frac{1}{64} \left[-2857 + \frac{5033}{9}n_f - \frac{325}{27}n_f^2 \right]. \end{aligned} \quad (\text{A.4})$$

Setting the number of flavors equal to 3, they have the values $\beta_1 = -9/2$, $\beta_2 = -8$, and $\beta_3 = -20.1198$. The parameter $\Lambda_{\overline{MS}}$ depends on the number of flavors n_f in such a way that $\alpha_s(\mu)$ is continuous across quark thresholds.

The running mass $m_i(\mu)$ can be expressed in terms of a scale invariant mass parameter \hat{m}_i as follows:

$$m_i(\mu) = \hat{m}_i \left(-\beta_1 \frac{\alpha_s(\mu)}{\pi} \right)^{-\gamma_1/\beta_1} \left\{ 1 + \frac{\beta_2}{\beta_1} \left(\frac{\gamma_1}{\beta_1} - \frac{\gamma_2}{\beta_2} \right) \frac{\alpha_s(\mu)}{\pi} + \frac{1}{2} \left[\frac{\beta_2^2}{\beta_1^2} \left(\frac{\gamma_1}{\beta_1} - \frac{\gamma_2}{\beta_2} \right)^2 - \frac{\beta_2^2}{\beta_1^2} \left(\frac{\gamma_1}{\beta_1} - \frac{\gamma_2}{\beta_2} \right) + \frac{\beta_3}{\beta_1} \left(\frac{\gamma_1}{\beta_1} - \frac{\gamma_3}{\beta_3} \right) \right] \left(\frac{\alpha_s(\mu)}{\pi} \right)^2 + O(\alpha_s^3) \right\}, \quad (\text{A.5})$$

where γ_i are the $O(\alpha_s^i)$ coefficients of the quark-mass anomalous dimension [45],

$$\begin{aligned} \gamma_1 &= 2, \\ \gamma_2 &= \frac{101}{12} - \frac{5}{18} n_f, \\ \gamma_3 &= \frac{1}{96} \left[3747 - \left(160\zeta(3) + \frac{2216}{9} \right) n_f - \frac{140}{27} n_f^2 \right]. \end{aligned} \quad (\text{A.6})$$

and $\zeta(3) = 1.2020569\dots$ is the Riemann zeta function at $n = 3$. Setting the number of flavors equal to 3, they have the values $\gamma_1 = 2$, $\gamma_2 = 91/12$, and $\gamma_3 = 24.8404$.

A.1. Dimension 0

For massless quarks, the perturbative contributions to the vector and axial-vector correlators $\Pi_{ij,V/A}^{(0+1)}(-Q^2)$ are known to $O(\alpha_s^3)$. The additive constant in $\Pi_{ij,V/A}^{(0+1)}(-Q^2)$ depends on the renormalization scheme and does not contribute to the contour integral (2.8). All of the physical information is carried in the logarithmic derivative

$$D_{ij,V/A}(-Q^2) \equiv -Q^2 \frac{d}{dQ^2} \Pi_{ij,V/A}^{(0+1)}(-Q^2), \quad (\text{A.7})$$

which satisfies a homogenous renormalization group equation. For the flavor nonsinglet correlators ($i \neq j$), one has $D_{ij,V}(-Q^2) = D_{ij,A}(-Q^2) \equiv D(-Q^2)$. The result for $D(s)$ expanded in powers of the running coupling constant $\alpha_s(\mu)$ is

$$D(-Q^2) = \frac{1}{4\pi^2} \left\{ 1 + \frac{\alpha_s(\mu)}{\pi} + \left[F_3 + \frac{\beta_1}{2} L \right] \left(\frac{\alpha_s(\mu)}{\pi} \right)^2 + \left[F_4 + \left(F_3 \beta_1 + \frac{\beta_2}{2} \right) L + \frac{\beta_1^2}{4} \left(L^2 + \frac{\pi^2}{3} \right) \right] \left(\frac{\alpha_s(\mu)}{\pi} \right)^3 + O(\alpha_s^4) \right\}, \quad (\text{A.8})$$

where $L \equiv \log(Q^2/\mu^2)$ and $F_3 = 1.6398$, $F_4 = -10.2839$ [17,18] for $n_f = 3$. The factors of β_i in (A.8) are such that the logarithms L can be absorbed into the running coupling constant simply by replacing the scale μ by Q .

Using integration by parts, the relevant term in the contour integral (2.8) can be written

$$R_\tau^{pert} = -12\pi i (|V_{ud}|^2 + |V_{us}|^2) \int_{|s|=M_\tau^2} \frac{ds}{s} \left(\frac{1}{2} - \frac{s}{M_\tau^2} + \frac{s^3}{M_\tau^6} - \frac{s^4}{2M_\tau^8} \right) D(s). \quad (\text{A.9})$$

In the expression (A.8) for $D(s)$, the only dependence on s appears in the logarithms L . Inserting (A.8) into (A.9), the contour integrals are straightforward to evaluate and they give the result (3.6).

A.2. Dimension 2

The dimension-2 contributions to the correlation functions (2.1) are simply the leading quark mass corrections to the perturbative QCD result. The only operators of dimension 2 are products of two running quark masses, $m_i(\mu)m_j(\mu)$. The coefficient functions have been calculated beyond leading order in refs. [20], [21], and [22].

The sum of the $J = 0$ and $J = 1$ coefficient functions satisfies a homogeneous differential equation which guarantees that all dependence on the factorization scale μ can be absorbed into the running coupling constant and the running masses [20,21]:

$$\begin{aligned} Q^2 \left[\Pi_{ij,V/A}^{(0+1)}(-Q^2) \right]^{(D=2)} &= -\frac{3}{8\pi^2} \left[1 + \frac{8}{3} \frac{\alpha_s(Q)}{\pi} \right] [m_i(Q) \pm m_j(Q)]^2 \\ &\quad - \frac{3}{8\pi^2} \left[1 + 2 \frac{\alpha_s(Q)}{\pi} \right] [m_i(Q) \mp m_j(Q)]^2. \end{aligned} \quad (\text{A.10})$$

The upper and lower signs correspond to the vector (V) and axial vector (A) currents, respectively, and $\alpha_s(Q)$ and $m_i(Q)$ denote the running coupling constant and the running mass evaluated at the spacelike momentum transfer Q^2 .

The $J = 0$ coefficient function [20,21] is

$$\begin{aligned} Q^2 \left[\Pi_{ij,V/A}^{(0)}(-Q^2) \right]^{(D=2)} &= \frac{3}{2\pi^2} \left[\left(\frac{\alpha_s(M_\tau)}{\pi} \right)^{-1} - \frac{5}{2} \right] [m_i(Q) \mp m_j(Q)]^2 \\ &\quad + \widehat{C}_{V/A}(\mu) [m_i(\mu) \mp m_j(\mu)]^2. \end{aligned} \quad (\text{A.11})$$

The constant $\widehat{C}_{V/A}(\mu)$ depends on how $\Pi_{ij,V/A}^{(0)}(-Q^2)$ is renormalized but does not contribute to physical quantities.

A.3. Dimension 4

The dynamical operators of dimension 4 are the gluonic field strength-squared $GG(\mu)^{\overline{MS}} = G_{\nu\lambda}^a G^{a\nu\lambda}(\mu)^{\overline{MS}}$ and the scalar quark density $\bar{\psi}_i\psi_i(\mu)^{\overline{MS}}$ multiplied by a running quark mass $m_j(\mu)$. These operators are defined by dimensional regularization and minimal subtraction of divergences and therefore depend on a renormalization scale

μ . The remaining $D = 4$ operators are products of 4 running quark masses. As discussed in Appendix B, one can form nontrivial linear combinations of the $D = 4$ operators that are scale invariant. The matrix elements of these scale invariant operators are called the gluon condensate, $\langle (\alpha_s/\pi)GG \rangle$, and the quark condensates, $\langle m_j \bar{\psi}_i \psi_i \rangle$.

The coefficient functions for the minimally subtracted dimension-4 operators have been calculated beyond leading order in refs. [22] and [23]. Their vacuum expectation values are expressed in terms of the scale invariant condensates $\langle (\alpha_s/\pi)GG \rangle$ and $\langle m_j \bar{\psi}_i \psi_i \rangle$ in Appendix B. Making those substitutions we find that the dimension -4 contributions to the correlators reduce to

$$\begin{aligned}
Q^4 \left[\Pi_{ij,V/A}^{(0+1)}(-Q^2) \right]^{(D=4)} &= \frac{1}{12} \left[1 - \frac{11}{18} \frac{\alpha_s(Q)}{\pi} \right] \langle \frac{\alpha_s}{\pi} GG \rangle \\
&+ \left[1 - \frac{\alpha_s(Q)}{\pi} - \frac{13}{3} \left(\frac{\alpha_s(Q)}{\pi} \right)^2 \right] \langle m_i \bar{\psi}_i \psi_i + m_j \bar{\psi}_j \psi_j \rangle \\
&\pm \left[\frac{4}{3} \frac{\alpha_s(Q)}{\pi} + \frac{59}{6} \left(\frac{\alpha_s(Q)}{\pi} \right)^2 \right] \langle m_j \bar{\psi}_i \psi_i + m_i \bar{\psi}_j \psi_j \rangle \\
&+ \left[\frac{4}{27} \frac{\alpha_s(Q)}{\pi} + \left(-\frac{257}{486} + \frac{4}{3} \zeta(3) \right) \left(\frac{\alpha_s(Q)}{\pi} \right)^2 \right] \sum_k \langle m_k \bar{\psi}_k \psi_k \rangle \\
&+ \frac{3}{2\pi^2} \left[1 + \left(\frac{76}{9} - \frac{4}{3} \zeta(3) \right) \frac{\alpha_s(Q)}{\pi} \right] m_i^2(Q) m_j^2(Q) \\
&+ \frac{1}{4\pi^2} \left[-\frac{12}{7} \left(\frac{\alpha_s(Q)}{\pi} \right)^{-1} + 1 \right] [m_i^4(Q) + m_j^4(Q)] \\
&\mp \frac{4}{7\pi^2} m_i(Q) m_j(Q) [m_i^2(Q) + m_j^2(Q)] \\
&- \frac{1}{28\pi^2} \left[1 - \left(\frac{65}{6} - 16\zeta(3) \right) \frac{\alpha_s(Q)}{\pi} \right] \sum_k m_k^4(Q),
\end{aligned} \tag{A.12}$$

and

$$\begin{aligned}
Q^4 \left[\Pi_{ij,V/A}^{(0)}(-Q^2) \right]^{(D=4)} &= \langle (m_i \mp m_j) (\bar{\psi}_i \psi_i \mp \bar{\psi}_j \psi_j) \rangle \\
&+ \frac{1}{4\pi^2} \left[-\frac{12}{7} \left(\frac{\alpha_s(Q)}{\pi} \right)^{-1} + \frac{11}{14} \right] [m_i(Q) \mp m_j(Q)] [m_i^3(Q) \mp m_j^3(Q)] \\
&\mp \frac{3}{4\pi^2} m_i(Q) m_j(Q) [m_i(Q) \mp m_j(Q)]^2.
\end{aligned} \tag{A.13}$$

A.4. Dimension 6

The most important dimension-6 operators are the 4-quark operators of the form $(\bar{\psi}_i \Gamma \psi_j \bar{\psi}_j \Gamma \psi_i)(\mu)$, where Γ is the product of a Dirac matrix γ_μ or $\gamma_\mu \gamma_5$ and a color

matrix, which is either the identity matrix 1 or an SU(3) generator T^a normalized so that $\text{tr}(T^a T^b) = \delta^{ab}/2$. The coefficient function of the dimension-6 operator $G^3(\mu) \equiv g^3 f^{abc} G_\mu^{a,\nu} G_\nu^{b,\lambda} G_\lambda^{c,\mu}$ vanishes to leading order in α_s [24], so we will neglect it. The other dimension-6 operators are lower dimension operators multiplied by running quark masses. Since these are severely suppressed by the quark masses, we shall omit them also.

The coefficient functions for the 4-quark operators were calculated to next-to-leading order in ref. [25]. In the chiral limit the longitudinal coefficient $sC^{(J=0)}$ vanishes, and the $J = 0 + 1$ term in the correlator is

$$\begin{aligned}
& Q^6 \left[\Pi_{ij,V/A}^{(0+1)}(-Q^2) \right]^{(D=6)} \\
&= -8\pi^2 \left[1 + \left(\frac{431}{96} - \frac{9}{8}L \right) \frac{\alpha_s(\mu)}{\pi} \right] \frac{\alpha_s(\mu)}{\pi} \langle \bar{\psi}_i \gamma_\mu \begin{pmatrix} \gamma_5 \\ 1 \end{pmatrix} T^a \psi_j \bar{\psi}_j \gamma^\mu \begin{pmatrix} \gamma_5 \\ 1 \end{pmatrix} T^a \psi_i(\mu) \rangle \\
&+ \frac{5\pi^2}{4} (3 + 4L) \left(\frac{\alpha_s(\mu)}{\pi} \right)^2 \langle \bar{\psi}_i \gamma_\mu \begin{pmatrix} 1 \\ \gamma_5 \end{pmatrix} T^a \psi_j \bar{\psi}_j \gamma^\mu \begin{pmatrix} 1 \\ \gamma_5 \end{pmatrix} T^a \psi_i(\mu) \rangle \\
&+ \frac{2\pi^2}{3} (3 + 4L) \left(\frac{\alpha_s(\mu)}{\pi} \right)^2 \langle \bar{\psi}_i \gamma_\mu \begin{pmatrix} 1 \\ \gamma_5 \end{pmatrix} \psi_j \bar{\psi}_j \gamma^\mu \begin{pmatrix} 1 \\ \gamma_5 \end{pmatrix} \psi_i(\mu) \rangle \\
&- \frac{8\pi^2}{9} \left[1 + \left(\frac{107}{48} - \frac{95}{72}L \right) \frac{\alpha_s(\mu)}{\pi} \right] \frac{\alpha_s(\mu)}{\pi} \\
&\quad \times \sum_k \langle (\bar{\psi}_i \gamma_\mu T^a \psi_i + \bar{\psi}_j \gamma_\mu T^a \psi_j) \bar{\psi}_k \gamma^\mu T^a \psi_k(\mu) \rangle \\
&+ \frac{5\pi^2}{54} (-7 + 6L) \left(\frac{\alpha_s(\mu)}{\pi} \right)^2 \sum_k \langle (\bar{\psi}_i \gamma_\mu \gamma_5 T^a \psi_i + \bar{\psi}_j \gamma_\mu \gamma_5 T^a \psi_j) \bar{\psi}_k \gamma^\mu \gamma_5 T^a \psi_k(\mu) \rangle \\
&+ \frac{4\pi^2}{81} (-7 + 6L) \left(\frac{\alpha_s(\mu)}{\pi} \right)^2 \sum_k \langle (\bar{\psi}_i \gamma_\mu \gamma_5 \psi_i + \bar{\psi}_j \gamma_\mu \gamma_5 \psi_j) \bar{\psi}_k \gamma^\mu \gamma_5 \psi_k(\mu) \rangle \\
&+ \frac{4\pi^2}{81} (1 + 6L) \left(\frac{\alpha_s(\mu)}{\pi} \right)^2 \sum_{k,l} \langle \bar{\psi}_k \gamma^\mu T^a \psi_k \bar{\psi}_l \gamma^\mu T^a \psi_l(\mu) \rangle,
\end{aligned} \tag{A.14}$$

where $L \equiv \log(Q^2/\mu^2)$. The upper component of $\begin{pmatrix} 1 \\ \gamma_5 \end{pmatrix}$ or $\begin{pmatrix} \gamma_5 \\ 1 \end{pmatrix}$ is for the vector (V) correlator, while the lower component is for the axial vector (A).

A.5. Dimension 8

In the chiral limit, the complete basis of $D = 8$ operators contributing to the vector correlator (2.1a) consists of 10 quark operators, 3 gluonic operators involving the color current $j_\alpha^a \equiv \sum_{u,d,s} \bar{\psi} \gamma_\alpha T^a \psi$, and 4 purely gluonic G^4 operators. The explicit form of these 17 operators can be found in ref. [30], where their coefficient functions have been computed at leading order.

Since no such calculation is available for the axial-vector correlator (2.1b), we will only

consider the effect of the G^4 operators:

$$\begin{aligned}
O_1 &\equiv g^4 \text{Tr}(G_{\mu\nu} G^{\mu\nu} G_{\alpha\beta} G^{\alpha\beta}), \\
O_2 &\equiv g^4 \text{Tr}(G_{\mu\nu} G_{\alpha\beta} G^{\mu\nu} G^{\alpha\beta}), \\
O_3 &\equiv g^4 \text{Tr}(G_{\mu\nu} G^{\nu\alpha} G_{\alpha\beta} G^{\beta\mu}), \\
O_4 &\equiv g^4 \text{Tr}(G_{\mu\nu} G_{\alpha\beta} G^{\nu\alpha} G^{\beta\mu}).
\end{aligned} \tag{A.15}$$

They should give the same contribution to the vector and axial-vector channels:

$$\begin{aligned}
Q^8 \left[\Pi_{ij,V/A}^{(0+1)}(-Q^2) \right]^{(D=8)} &\approx \frac{1}{216\pi^2} \log\left(\frac{Q^2}{\mu^2}\right) \langle -5 O_1 + O_2 + 10 O_3 + 6 O_4 \rangle \\
&+ \frac{1}{2592\pi^2} \langle -19 O_1 - 193 O_2 - 262 O_3 + 558 O_4 \rangle.
\end{aligned} \tag{A.16}$$

Appendix B. SCALE INVARIANT $D = 4$ OPERATORS

The perturbative evaluation of quark-mass corrections to the correlation functions (2.1a, b) gives rise to infrared logarithms of the form $m^4 \alpha_s(\mu)^n \log^k(\frac{m}{\mu})$ ($k \leq n+1$), where μ is the \overline{MS} renormalization scale. These mass singularities arise from the region of small loop momenta in the relevant Feynman diagrams, and therefore should be factorized into the matrix elements $\langle \mathcal{O}(\mu) \rangle$. The infrared logarithms are nothing else than the perturbative contributions (renormalized in the \overline{MS} scheme) to the vacuum expectation values of the $D = 4$ operators:

$$\langle GG(\mu) \rangle_{\text{pert}}^{\overline{MS}} = -\frac{1}{2\pi^2} \frac{\alpha_s(\mu)}{\pi} \sum_k m_k(\mu)^4 \left[9 - 16 \log \frac{m_k(\mu)}{\mu} + 12 \log^2 \frac{m_k(\mu)}{\mu} \right], \tag{B.1a}$$

$$\begin{aligned}
\langle \bar{\psi}_i \psi_i(\mu) \rangle_{\text{pert}}^{\overline{MS}} &= \frac{1}{4\pi^2} m_i(\mu)^3 \left\{ \left[3 - 6 \log \frac{m_k(\mu)}{\mu} \right] \right. \\
&\quad \left. + \left[10 - 20 \log \frac{m_k(\mu)}{\mu} + 24 \log^2 \frac{m_k(\mu)}{\mu} \right] \frac{\alpha_s(\mu)}{\pi} \right\}.
\end{aligned} \tag{B.1b}$$

This does not imply that the complete matrix elements $\langle GG(\mu) \rangle$ and $\langle \bar{\psi}_i \psi_i(\mu) \rangle$ only have perturbative contributions. In addition to the small perturbative contributions (B.1a, b), they also have large nonperturbative contributions due to the complicated structure of the QCD vacuum.

Note that the calculation of the leading ($D = 2$) quark-mass corrections does not produce any logarithms $\log^k(m/\mu)$. The absence of such mass-singularities in the m^2 terms is guaranteed by the absence of $D = 2$ operators in QCD.

To facilitate the summation of the logarithms $\log(Q/\mu)$ using the renormalization group, it is convenient to introduce combinations of the minimally subtracted operators

$GG(\mu)^{\overline{MS}}$ and $\bar{\psi}_i\psi_i(\mu)^{\overline{MS}}$ which are scale-invariant. These combinations are called the gluon and quark condensates. For $n_f = 3$, the perturbative expressions [46,22] for these condensates are

$$\begin{aligned} \langle \frac{\alpha_s}{\pi} GG \rangle &\equiv \left(1 + \frac{16}{9} \frac{\alpha_s(\mu)}{\pi} + O(\alpha_s^2) \right) \frac{\alpha_s(\mu)}{\pi} \langle GG(\mu) \rangle^{\overline{MS}} \\ &\quad - \frac{16}{9} \frac{\alpha_s(\mu)}{\pi} \left(1 + \frac{91}{24} \frac{\alpha_s(\mu)}{\pi} + O(\alpha_s^2) \right) \sum_k m_k(\mu) \langle \bar{\psi}_k\psi_k(\mu) \rangle^{\overline{MS}} \\ &\quad - \frac{1}{3\pi^2} \left(1 + \frac{4}{3} \frac{\alpha_s(\mu)}{\pi} + O(\alpha_s^2) \right) \sum_k m_k^4(\mu), \end{aligned} \quad (\text{B.2a})$$

$$\begin{aligned} \langle m_i \bar{\psi}_j\psi_j \rangle &\equiv m_i(\mu) \langle \bar{\psi}_j\psi_j(\mu) \rangle^{\overline{MS}} \\ &\quad + \frac{3}{7\pi\alpha_s(\mu)} \left(1 - \frac{53}{24} \frac{\alpha_s(\mu)}{\pi} + O(\alpha_s^2) \right) m_i(\mu) m_j^3(\mu). \end{aligned} \quad (\text{B.2b})$$

Note the presence of an inverse power of the coupling constant in the expression for the quark condensate.

The coefficient functions in the OPE of the minimally subtracted operators $GG(\mu)^{\overline{MS}}$ and $m_i(\mu)\bar{\psi}_j\psi_j(\mu)^{\overline{MS}}$ were calculated beyond leading order in refs. [23] and [22]. After expressing their results in terms of the scale-invariant condensates $\langle \frac{\alpha_s}{\pi} GG \rangle$ and $\langle m_i \bar{\psi}_j\psi_j \rangle$ defined above, the coefficient functions satisfy homogenous renormalization group equations. The logarithms $\log(Q/\mu)$ can then be easily summed into the running coupling constant $\alpha_s(Q)$ and the running mass $m_i(Q)$, and one obtains the results given in eqs. (A.12) and (A.13).

References

- [1] A.Pich, "QCD Tests from Tau-Decay Data", in Proc. Tau-Charm Factory Workshop (SLAC, 1989), ed. L.V.Beers, SLAC-Report-343 (1989), p. 416.
- [2] K.Schilcher and M.D.Tran, Phys. Rev. D29 (1984) 570.
- [3] E.Braaten, Phys.Rev.Lett. 60 (1988) 1606.
- [4] S.Narison and A.Pich, Phys. Lett. B211 (1988) 183.
- [5] E.Braaten, Phys. Rev. D39 (1989) 1458.
- [6] E.Braaten, "Applying QCD to Inclusive Decay Rates of the τ Lepton", in Proc. Tau-Charm Factory Workshop (SLAC, 1989), ed. L.V.Beers, SLAC-Report-343 (1989), p. 408.
- [7] A.Pich, "Hadronic Tau-Decays and QCD", in Proc. Workshop on Tau Lepton Physics (Orsay 1990), eds. M.Davier and B.Jean-Marie, Ed. Frontières 1991.
- [8] A.Pich, Mod. Phys. Lett. A5 (1990) 1995.
- [9] A.Pich, "Tau Physics", CERN-TH.6237/91 (to appear in "Heavy Flavours", eds. A.J.Buras and M.Lindner, Advanced Series on Directions in High Energy Physics, World Scientific, 1991).
- [10] C.S.Lam and T.M.Yan, Phys. Rev. D16 (1977) 703;
T.Appelquist, Lectures at the Banff Summer Institute, Alberta, Canada (1977);
S.Narison, Z.Phys. C2 (1979) 11.
- [11] R.Shankar, Phys. Rev. D15 (1977) 755;
E.G.Floratos, S.Narison and E. de Rafael, Nucl. Phys. B155 (1979) 115;
O.Nachtmann and W.Wetzel, Phys. Lett. 81B (1979) 229;
S.Narison and E.de Rafael, Nucl. Phys. B169 (1980) 253;
N.V.Krasnikov, A.A.Pivovarov and A.N.Tavkhelidze, Z.Phys. C19 (1983) 301;
R.A.Bertlmann, G.Launer and E.de Rafael, Nucl. Phys. B250 (1985) 61.
- [12] M.A.Shifman, A.L.Vainshtein and V.I.Zakharov, Nucl. Phys. B147 (1979) 385, 448, 519.
- [13] J.Pumplin, Phys. Rev. Lett. 63 (1989) 576; Phys. Rev. D41 (1990) 900.
- [14] K.G.Chetyrkin, A.L.Kataev and F.V.Tkachov, Phys. Lett. 85B (1979) 277;
M.Dine and J.Sapirstein, Phys. Rev. Lett. 43 (1979) 668;
W.Celmaster and R.Gonsalves, Phys. Rev. Lett. 44 (1980) 560.
- [15] S.G.Gorishny, A.L.Kataev and S.A.Larin, Phys.Lett. B212 (1988) 238.
- [16] A.L.Kataev, Montpellier preprint PM/90-41 (to appear in Proc. QCD 90 Conference, Montpellier 1990, ed. S.Narison).
- [17] S.G.Gorishny, A.L.Kataev and S.A.Larin, Phys. Lett. B259 (1991) 144.
- [18] L.R.Surguladze and M.A.Samuel, Phys. Rev. Lett. 66 (1991) 560.
- [19] T.L.Trueman, Phys. Lett. 88B (1979) 331;
A.I.Antoniadis, Phys. Lett. 84B (1979) 223.

- [20] C.Becchi, S.Narison, E.de Rafael and F.J.Yndurain, *Z.Phys.* C8 (1981) 335.
- [21] D.J.Broadhurst, *Phys. Lett.* 101B (1981) 423.
- [22] D.J.Broadhurst and S.C.Generalis, Open University preprint OUT-4102-12 (1984) (unpublished);
S.C.Generalis, *J. Phys.* G15 (1989) L225.
- [23] K.G.Chetyrkin, S.G.Gorishny and V.P.Spiridonov, *Phys. Lett.* 160B (1985) 149.
- [24] W.Hubshmid and S.A.Mallik, *Nucl. Phys.* B207 (1982) 29;
M.S.Dubovikov and A.V.Smilga, *Nucl. Phys.* B185 (1981) 109.
- [25] L.V.Larin, V.P.Spiridonov and K.G.Chetyrkin, *Yad. Fiz.* 44 (1986) 1372 [*Sov. J. Nucl. Phys.* 44 (1986) 892].
- [26] R.Tarrach and S.Narison, *Phys. Lett.* B125 (1983) 217;
M.Jamin and M.Kremmer, *Nucl. Phys.* B277 (1986) 349.
- [27] G.Launer, S.Narison and R.Tarrach, *Z.Phys.* C26 (1984) 433;
Y.Chung et al. , *Z.Phys.* C25 (1984) 151;
M.Kremer, N.A.Papadopoulos and K.Schilcher, *Phys. Lett.* 143B (1984) 476;
R.A.Bertlmann et al., *Z.Phys.* C39 (1988) 231.
- [28] C.A.Domínguez and J.Solá, *Z.Phys.* C40 (1988) 63.
- [29] V.Giménez, J.A.Peñarrocha and J.Bordes, *Phys. Lett.* B223 (1989) 221; *Nucl. Phys.* B357 (1991) 3.
- [30] D.J.Broadhurst and S.C.Generalis, *Phys. Lett.* 165B (1985) 175.
- [31] E.Bagàn, J.I.Latorre, P.Pascual and R.Tarrach, *Nucl. Phys.* B254 (1985) 555.
- [32] E.Braaten and C.S.Li, *Phys. Rev.* D42 (1990) 3888.
- [33] W.J.Marciano and A.Sirlin, *Phys. Rev. Lett.* 61 (1988) 1815.
- [34] W.J.Marciano and A.Sirlin, *Phys. Rev. Lett.* 56 (1986) 22.
- [35] J.Chýla, A.Kataev and S.Larin, Michigan Univ. preprint UM-TH-91-06.
- [36] A.H.Mueller, *Nucl. Phys.* B250 (1985) 327.
- [37] J.D.Bjorken, SLAC preprint SLAC-PUB-5103 (October, 1989).
- [38] G.B.West, in *Radiative Corrections*, ed. N.Dombey and F.Boudjema (Plenum Press, 1990); Los Alamos preprints LA-UR-91-662 and LA-UR-91-1301.
- [39] P.A.Raczka, *Phys. Rev.* D43 (1991) R9.
- [40] S.Narison, "QCD Spectral Sum Rules" (Lecture Notes in Physics, Vol.26), World Scientific, Singapore 1989.
- [41] C.A.Dominguez and E.de Rafael, *Ann. Phys.* 174 (1987) 372;
C.A.Dominguez, C. van Gend and N.Paver, *Phys. Lett.* B253 (1991) 241.
- [42] M.Aguilar-Benítez et al., "Review of Particle Properties", *Phys. Lett.* B239 (1990) 1.
- [43] T.Hebbeker, plenary talk at the LP-HEP91 Conference, Geneva, July 1991.
- [44] O.V.Tarasov, A.A.Vladimirov and A.Yu.Zharkov, *Phys. Lett.* B93 (1980) 429.

- [45] O.V.Tarasov, Dubna preprint JINR R2-82-900 (1982);
S.G.Gorishnii, A.L.Kataev and S.A.Larin, Yad. Fiz. 40 (1984) 517 [Sov. J. Nucl. Phys.
40 (1984) 329];
R.Tarrach, Nucl. Phys. B183 (1981) 384.
- [46] V.P.Spiridonov and K.G.Chetyrkin, Yad. Fiz. 47 (1988) 818 [Sov.J. Nucl. Phys. 47
(1988) 522].