

1 Modelling mass transfer properties in a biotrickling filter for the removal of isopropanol

2 Pau San-Valero, Josep M. Peña-Roja, F. Javier Álvarez-Hornos and Carmen

3 Gabaldón*

4 Research Group GI²AM, Department of Chemical Engineering, University of Valencia,

5 Avda. Universitat s/n, 46100 Burjassot, Spain

6 *Corresponding author: Tel. +34 96 354 34 37, Fax: +34 96 354 48 98, E-mail address:

7 carmen.gabaldon@uv.es

8 Abstract

9 A study was carried out to model mass transfer properties in biotrickling filters, treating
10 isopropanol as the target pollutant. This study was extended to the mass transfer of
11 oxygen related to the fact that the treatment of hydrophilic compounds by biotrickling
12 filtration is often limited by oxygen. A simple method for each compound was
13 developed based on their physical properties. The influence of temperature on the
14 Henry's law constant of isopropanol was determined. An increase of 1.8 per 10°C for
15 the dimensionless Henry's law constant was obtained. The determination of the overall
16 mass transfer coefficients of isopropanol (K_{Ga}) was carried out, obtaining values
17 between 500 and 1800 h⁻¹ for gas velocities of 100 and 300 m h⁻¹. No significant
18 influences were observed for either the liquid velocity or packing material. Also, the
19 determination of overall mass transfer coefficients of oxygen (K_{La}) were carried out,
20 obtaining values between 20 and 200 h⁻¹ depending on the packing material for liquid
21 velocities between 2 and 33 m h⁻¹. Structured packing materials exhibited greater mass
22 transfer coefficients, while for random packing materials, the mass transfer coefficients

23 clearly benefited from the high specific surface area. Mathematical correlations found in
24 the literature were compared with the empirical data, showing that neither was capable
25 of reproducing the mass transfer coefficients obtained empirically. Thus, empirical
26 relationships between the mass transfer coefficients and the gas and liquid velocities are
27 proposed to characterise the system.

28 **Keywords**

29 **Bioreactors; Mass transfer; Mathematical modelling; Bioprocess; Hydrodynamics**

30 **1. Introduction**

31 In recent decades, there has been an emergent interest in research into biotreatment as
32 an alternative for the treatment of volatile organic compounds (VOC), which includes
33 the biotrickling filter as one of the most applicable technologies (Devinny et al., 1999).
34 The use of biotrickling filtration for the treatment of VOC it is frequent and has been
35 shown to be capable of achieving high removal efficiencies. Considering that
36 biotrickling filtration involves a series of complex physical, chemical and biological
37 processes, further work is needed to determine the mechanisms that contribute to the
38 observed behaviour (Iranpour et al., 2005). The most representative mechanisms in a
39 biotrickling filter are mass transfer, diffusion and biological degradation. Typically, the
40 process may be limited by mass transfer as well as kinetics. Unfortunately, research has
41 been mainly focused on biodegradation kinetics rather than mass transfer (Dorado et al.,
42 2009; Lebrero et al., 2012) and, despite being a key step in the process, the optimisation
43 of mass transfer between the gas and the liquid/biofilm remains one of the most difficult
44 aims to achieve. Relating to this, several authors (Dorado et al., 2009; Kim and
45 Deshusses, 2008a) have emphasised the need to determine the mass transfer coefficients
46 in order to develop simulations for the design and optimisation of biotrickling filters.

47 Also, determining the mass transfer coefficient would facilitate the selection of the
48 packing material and the modelling of bioreactors used for air pollution control.

49 As pointed by other authors (Dorado et al., 2009; Kim and Deshusses, 2008a; Pérez et
50 al., 2006), the hydrodynamic conditions used in biofiltration are markedly different than
51 those used in absorption processes, so the typical correlations used in these systems are
52 not useful for predicting the phenomena occurring in biotrickling filters. Dorado et al.
53 (2009) confirmed that using experimental global mass transfer coefficients appears to be
54 the most suitable way to represent mass transfer in biotrickling filter systems; they
55 pointed out the need for using the target pollutant for the determination of mass transfer
56 coefficients.

57 Isopropanol is a hydrophilic compound typified by its high volatility and relatively low
58 hazardous properties in comparison with other solvents. As a result, it is one of the most
59 commonly used solvents in chemical industries as coating, printing, cleaning, among
60 others, resulting in a large amount of emissions to the atmosphere that should be treated.
61 Due to its low Henry's law constant in comparison with the Henry's law constant of
62 oxygen, its treatment by biofiltration implies that the process could be typically limited
63 by the low concentration of oxygen in the biofilm. This could imply that that the
64 penetration depth of oxygen in water or the biofilm is lower than that of the pollutant,
65 causing anaerobic zones in the deeper parts of the biofilm close to the substratum
66 (Shareefdeen and Singh, 2005). Experiments based on the physical properties of the gas
67 and liquid phases have shown that the volumetric mass transfer coefficient could be
68 influenced by the liquid phase at a similar level of contribution than the influence of the
69 gas (Pérez et al., 2006). So, both influences should be assessed in order to characterise
70 and improve the process.

71 The purpose of this research was to determine the mass transfer coefficients for the
72 treatment of hydrophilic compounds using isopropanol and oxygen as reference
73 components for various packing materials. To carry out this purpose, the following
74 objectives were developed: (1) to establish a simple method to determine the mass
75 transfer coefficients of typical hydrophilic compounds using isopropanol as the target
76 pollutant, (2) to establish a simple method to determine the mass transfer coefficients of
77 oxygen, (3) to determine the influence of gas and liquid velocities on the mass transfer
78 coefficients and (4) to establish a mathematical relationship between the mass transfer
79 coefficients and the operational conditions.

80

81 2. Materials and methods

82

83 2.1 Theory

84 The overall mass transfer coefficient expressed in the liquid phase is defined as a
85 function of the individual mass transfer coefficients, and is related to the overall mass
86 transfer coefficient expressed in the gas phase, according to Eq. (1)

$$87 \quad \frac{1}{K_L a} = \frac{1}{HK_G a} = \frac{1}{k_L a} + \frac{1}{Hk_G a} \quad (1)$$

88 Depending of the Henry's law constant of the substance, the main resistance to the
89 transfer could be controlled only by one of these phases. Liss and Slater (1974)
90 established that for Henry's law constants over 250 atm (mole fraction)⁻¹, the main
91 resistance is controlled by the liquid film, while for Henry's law constants between 1
92 and 250 atm (mole fraction)⁻¹, the main resistance is a mix between the two phases, and
93 for Henry's law constants up to 1 atm (mole fraction)⁻¹, the resistance is controlled by
94 the gas film. Due to the existing differences between the Henry's law constant of

95 isopropanol (0.460 ± 0.124 atm (mole fraction)⁻¹ (Sander, 2005)) and oxygen
96 (43922 ± 1679 atm (mole fraction)⁻¹), two different methods were developed to measure
97 the mass transfer coefficients for each compound.

98

99 2.2 Determination of the mass transfer coefficient of isopropanol

100 2.2.1 Experimental set-up

101 As shown in Fig. 1, the system consisted of a column of methacrylate (14.4 cm internal
102 diameter, 120 cm height) and a recirculation tank (5 L water volume). Two packing
103 materials, one random (Flexiring 25mm) and one structured (PAS Winded Media), were
104 investigated; the characteristics of these materials are shown in Table 1. The packing
105 height was 100 cm. The air stream (compressed, filtered and dried) was introduced
106 through the bottom of the column, with the flow rate adjusted using a mass flow
107 controller (Bronkhorst Hi-Tec, The Netherlands). The experiments were carried out at
108 three superficial air velocities around 100, 150 and 300 m h⁻¹ and the trickling water was
109 recirculated using a centrifugal pump (HPR10/15, ITT, Great Britain) in counter-current
110 mode with respect to the air flow rate, with a superficial water velocity of 2, 4, 7 and 13
111 m h⁻¹. The operational conditions were selected in order to evaluate the wide range used
112 in biotrickling filters. The experiments were carried out at room temperature ($21.5 \pm$
113 1.3°C). For isopropanol, these changes in temperature imply variations in the Henry's
114 law constants of up to 20-25% (Sander, 2005); thus, the dependence of H on
115 temperature had to be obtained for an accurate study of mass transfer.

116 The concentration of isopropanol was measured using a total hydrocarbon analyser
117 (Nira Mercury 901, Spirax Sarco, Spain). The response factor of the total hydrocarbon

118 analyser was determined by gas chromatography (model 7890, Agilent Technologies,
119 EEUU). The determination of the total organic carbon (TOC) in water was measured
120 using a Total Organic Carbon Analyser (TOC-V_{CHS}, Shimadzu Corporation, Japan).

121

122 2.2.2 Experimental procedure

123 A method under inert conditions was used for the determination of the overall mass
124 transfer coefficients of isopropanol. This method consisted of monitoring the
125 concentration of isopropanol in the gas phase during entire experiment and periodically
126 taking samples from the bottom of the column and water tank. To minimise the effect of
127 adsorption in the packing surface and the absorption in the water inside the reactor, the
128 system was previously wetted and saturated with isopropanol. When the inlet
129 concentration was equal to the outlet concentration, a continuous trickle began from the
130 tank to the top of the column. The first 20 minutes of each experiment were neglected to
131 ensure that stable conditions were achieved. After 20 minutes, the gas concentration as
132 well as the liquid concentration at the bottom of the column and in the tank were
133 considered as the initial points of the experiment and were used to estimate the value of
134 the mass transfer coefficients. Under these conditions, mass balances of isopropanol
135 were developed based on the following assumptions: (1) the behaviour of the column
136 was described as a plug flow regime; (2) the water tank was perfectly mixed; (3)
137 reaction in pipes was negligible, so, the concentration of the water tank was the same as
138 the concentration of the inlet of the column.

139 Mass balance in the packed column

140 For each time point and for a differential column of the reactor, the total amount of
141 carbon transferred from the gas to the liquid phase in the column is defined by:

$$dC_{G, IPA} = -\frac{Q_L}{Q_G} dC_{L, IPA} \quad (2)$$

where $C_{G, IPA}$ and $C_{L, IPA}$ are the gas/liquid concentrations and Q_G and Q_L are the volumetric flow rates in the gas/liquid phases, respectively.

From the integration of Eq. (2), the following equation is obtained:

$$C_{L_B, IPA} = C_{L_A, IPA} + \frac{Q_G}{Q_L} \cdot (C_{G_{in}, IPA} - C_{G_{out}, IPA}) \quad (3)$$

To determine the outlet concentration in the gas phase, the mass balance is described as:

$$Q_G \cdot dC_{G, IPA} = -H_{IPA} K_{GA} \cdot (C_{L, IPA}^* - C_{L, IPA}) \cdot dV_c \quad (4)$$

where V_c is the volume of the column, H_{IPA} is the dimensionless Henry's law constant of isopropanol expressed as concentration of gas phase/concentration of the liquid phase and $C_{L, IPA}^*$ is defined by Henry's Law according to Eq. (5).

$$C_{L, IPA}^* = \frac{C_{G, IPA}}{H_{IPA}} \quad (5)$$

Taking into account Eq. (5) and that the cross-sectional area of the column is constant, Eq. (4) can be written as follows:

$$Q_G \frac{dC_{G, IPA}}{dz} = -H_{IPA} K_{GA} \cdot S \left(\frac{C_{G, IPA}}{H_{IPA}} - C_{L, IPA} \right) \quad (6)$$

where S and z are the surface and the distance from the bottom of the column, respectively. The following boundary conditions were assumed. At the bottom of the column ($z=0$):

159

$$\begin{aligned}
C_{G,IPA} &= C_{G_{in},IPA} \\
C_{L,IPA} &= C_{L_B,IPA}
\end{aligned}
\tag{7}$$

while at the top of the column ($z=Z$)

$$\begin{aligned}
C_{G,IPA} &= C_{G_{out},IPA} \\
C_{L,IPA} &= C_{L_A,IPA}
\end{aligned}
\tag{8}$$

where $C_{G_{in},IPA}$ and $C_{G_{out},IPA}$ are the inlet/outlet concentrations in the gas phase and $C_{L_A,IPA}$ and $C_{L_B,IPA}$ are the liquid concentrations at the top and at the bottom of the column. The concentration at the top of the column is assumed to be equal to the concentration in the tank. Integrating Eq. (6) and with the conditions presented in Eqs. (7) and (8), the following equation was obtained:

$$\ln \left(\frac{C_{G_{out},IPA} - H_{IPA} \cdot C_{L_A,IPA}}{C_{G_{in},IPA} - H_{IPA} \cdot C_{L_B,IPA}} \right) = - \left(1 + H_{IPA} \frac{Q_G}{Q_L} \right) \frac{K_{Ga}}{Q_G} \cdot S \cdot Z
\tag{9}$$

Combining Eq. (9) and Eq. (3), the outlet concentration is described by:

$$C_{G_{out},IPA} = \frac{\left(1 - H_{IPA} \frac{Q_G}{Q_L} \right) \exp \left(- \left(1 + H_{IPA} \frac{Q_G}{Q_L} \right) \frac{K_{Ga}}{Q_G} \cdot S \cdot Z \right) C_{G_{in},IPA} + \left(1 - \exp \left(- \left(1 + H_{IPA} \frac{Q_G}{Q_L} \right) \frac{K_{Ga}}{Q_G} \cdot S \cdot Z \right) \right) \cdot H_{IPA} \cdot C_{L_A,IPA}}{1 - H_{IPA} \frac{Q_G}{Q_L} \exp \left(- \left(1 + H_{IPA} \frac{Q_G}{Q_L} \right) \frac{K_{Ga}}{Q_G} \cdot S \cdot Z \right)}
\tag{10}$$

Mass balance in the tank

The variation of $C_{L_A,IPA}$ and $C_{L_B,IPA}$ is described by the mass balance in the tank as

follows:

176
$$\frac{dC_{L_A,IPA}}{dt} = \frac{Q_L}{V_T} (C_{L_B,IPA} - C_{L_A,IPA}) \quad (11)$$

177 where V_T is the volume of the tank.

178 As was previously mentioned, the variations in temperature during the experiment
 179 imply variations in the Henry's law constants up to 20-25% (Sander, 2005). For this
 180 reason, the estimation of the parameters was divided into two stages. First, the
 181 estimation of K_Ga and H was carried out for the experiments with Flexiring 25 mm.
 182 These fitted values of H were related to the temperature and an empirical correlation
 183 between H and T was obtained. Second, the empirical correlation between H and T was
 184 used in each experiment of the structured packing material, thus the K_Ga was the only
 185 parameter to be fitted in this step.

186 2.3 Determination of the mass transfer coefficient of oxygen

187 2.3.1 Experimental set-up

188 As is shown in Fig. 2, a similar set-up as that used for the determination of the mass
 189 transfer coefficient of isopropanol was used but with a volume of 10 L in the
 190 recirculation tank. In this case, the study was extended to three packing materials, two
 191 random (Flexiring 25mm and Refilltech 15 mm) and one structured (PAS Winded
 192 Media); the characteristics are shown in Table 1. The packing height was 40 cm for the
 193 random packing materials and 20 cm for the structured packing material. The
 194 experiments were carried out at two superficial air velocities of 104 m h⁻¹ and 312 m h⁻¹.
 195 The trickling water was recirculated using a centrifugal pump with a superficial water
 196 velocity between 3 and 33 m h⁻¹. The equipment was supplemented with a dissolved
 197 oxygen probe (Cellox® 325i, WTW, Germany) to measure the dissolved oxygen

198 concentration in the tank. An internal pump installed in the recirculation tank ensured
199 the ideal mixing conditions. The experiments were carried out at room temperature
200 ($21.2 \pm 0.7^\circ\text{C}$). For oxygen, this implies variations in the Henry's law constant up to 2%
201 (Sander, 2005), thus the dependence of H on temperature was neglected.

202 2.3.2 Experimental procedure

203 For the determination of $K_L a$, a dynamic method under inert conditions was used as
204 described elsewhere (San-Valero et al., 2013). The method consisted of measuring the
205 increase in the oxygen concentration over time in a tank in which the oxygen was
206 previously displaced by bubbling nitrogen gas. The experiment started when the air
207 blower and the recirculation pump were switched on; oxygen was transferred from the
208 air to the water in the packed column, causing an increase in the dissolved oxygen
209 concentration in the recirculation tank. The oxygen mass balances were developed using
210 the same assumptions as isopropanol.

211 Mass balance in the packed column

$$212 \quad C_{L_B, OXY} = C_{L, OXY}^* - \frac{C_{L, OXY}^* - C_{L_A, OXY}}{\exp\left(\frac{Z}{v} K_L a\right)} \quad (12)$$

213 Where $C_{L_B, OXY}$ is the predicted dissolved oxygen concentration at the bottom of the
214 column, $C_{L_A, OXY}$ is the predicted dissolved oxygen concentration in the recirculation
215 tank, $C_{L, OXY}^*$ is the oxygen solubility and Z and v are the height of the column and the
216 velocity of the trickling water, respectively.

217 In the tank:

$$\frac{dC_{L_A, OXY}}{dt} = \frac{Q_L}{V_T} (C_{L_B, OXY} - C_{L_A, OXY}) \quad (13)$$

The combination of Eqs. (12) and (13) permits obtaining the variation of the predicted oxygen concentration over time (Van't Riet, 1979):

$$\frac{dC_{L_A, OXY}}{dt} = \frac{Q_L}{V_T} \left(C_{L, OXY}^* - \frac{C_{L, OXY} - C_{L_A, OXY}}{\exp\left(\frac{Z}{v} K_L a\right)} - C_{L_A, OXY} \right) \quad (14)$$

The response time constant of the probe, τ , is defined as the time at which the probe achieves 63% of the end value measured when the probe is subjected to a step input assay (Van't Riet, 1979). It was determined by transferring the oxygen probe from an ideal mixed tank in which the dissolved oxygen concentration was displaced by bubbling nitrogen gas to a second tank which was saturated with dissolved oxygen. First order dynamics were assumed according to Eq. (15) (Weiland and Onken, 1981)

$$\frac{dC_{L_m, OXY}}{dt} = \frac{(C_{L_A, OXY} - C_{L_m, OXY})}{\tau} \quad (15)$$

where $C_{L_m, OXY}^*$ is the dissolved oxygen concentration in the recirculation tank measured by the oxygen probe.

The value of $K_L a$ of the packed column was calculated by minimising the sum of squares of the difference between the measured data recorded for the dissolved oxygen concentration in the recirculation tank and the value obtained from the mathematical resolution of Eqs. (14) and (15).

235

236 3. Results and discussion

237 3.1 Determination of the mass transfer coefficient of isopropanol

238 3.1.1 Correlation between the Henry's law constant and the temperature

239 The determination of the mass transfer coefficient of isopropanol was carried out for
240 two packing materials: Flexiring 25 mm and PAS Winded Media. As the influence of
241 the temperature on the Henry's law constant of isopropanol should not be neglected, the
242 first set of experiments with the packing material Flexiring 25 mm were used for the
243 estimation of $K_G a$ and H . This estimation allowed for obtaining the exact temperature
244 dependence of the system with the Henry's law constant. The values of H^*_{298K} and the
245 enthalpy of the solution divided by the ideal gas law constant were obtained by using
246 the least squares method in order to minimise the differences between the experimental
247 data and the Van't Hoff equation. The parameters H^*_{298K} and the enthalpy of the
248 solution divided by the ideal gas law constant obtained are shown in Eq. (16)

$$249 \quad H^*_{T,IPA} = 146 \cdot \exp\left(5501 \cdot \left(\frac{1}{T} - \frac{1}{298}\right)\right) \quad (16)$$

250 where $H^*_{T,IPA}$ is the Henry's law constant expressed in $M \text{ atm}^{-1}$ and T is the temperature
251 expressed in K . The dimensionless Henry's law constant could be related with the
252 Henry's law constant expressed in $M \text{ atm}^{-1}$ by the following equation:

$$253 \quad H_{IPA} = \frac{1}{H^*_{T,IPA} RT} \quad (17)$$

254 where R is the universal gas constant ($0.082 \text{ atm K}^{-1} \text{ M}^{-1}$).

255 Fig. 3 shows the experimental data with the results provided by the empirical
256 correlation described by the Eq. (16). The available data from literature is also plotted
257 (Snider and Dawson, 1985). The general variation range of the dimensionless Henry's
258 law constant for VOC from 1.12 to 3.55 per 10°C rise in temperature, with an average

259 value of 1.88 found by Staudinger and Roberts (2001). The empirical correlation of Eq.
260 (16) presented an increase in the dimensionless Henry's law constant of 1.8 per each
261 10°C while Snider and Dawson (1985) provides a variation of 2.25 per 10° C rise. It is
262 common to find some discrepancies in the literature for the same compound related with
263 the influence of non-temperature effects on the Henry's law constant such as pH,
264 dissolved salts, etc (Staudinger and Roberts, 1996). Regarding this, Staudinger and
265 Roberts (2001) pointed out that it appears prudent to determine the exact temperature of
266 each case. Thus, the empirical correlation obtained in Eq. (16) was used to obtain the
267 value of H in the experiments carried out with the structured packing material.

268

269 3.1.2 K_Ga calculations

270 Typical examples of the raw data obtained from the experiments for each packing
271 material and the results of the data obtained with the mathematical model are shown in
272 Fig. 4. The experiment presented in Fig. 4a corresponds to one test carried out with the
273 packing material Flexiring 25 mm operating at a gas velocity of 180 m h⁻¹ and a liquid
274 velocity of 6.3 m h⁻¹ while the experiment presented in Fig. 4b corresponds to one test
275 carried out with the packing material PAS Winded Media operating at a gas velocity of
276 180 m h⁻¹ and a liquid velocity of 1.8 m h⁻¹. These examples were representative of all
277 tests done. The goodness of fit of the experimental data and the data provided by the
278 mathematical model were tested by using the relative error of the concentration of each
279 phase. An average value of the relative error of 6 % for the gas phase and an average
280 error of 5 % for the liquid phase (C_{L_A}, C_{L_B}) were obtained. The relative error obtained
281 indicated that the method was accurate for the determination of the mass transfer
282 coefficient of isopropanol.

283 The effect of the gas and liquid velocities for both packing materials is shown in Fig. 5.
284 Depending on the packing material and the conditions, K_Ga values were obtained in a
285 range between 500 and 1800 h^{-1} for gas velocities between 100 and 300 m h^{-1} and for
286 liquid velocities between 2 and 13 m h^{-1} . These data are on the same order of magnitude
287 as the data presented by Kim and Deshusses (2008a). These authors showed that for
288 biotrickling filters operating at a typical range of gas velocities below 500 m h^{-1} , the k_Ga
289 values were between 500 and 2000 h^{-1} . As shown in Fig. 5, the mass transfer coefficient
290 of isopropanol was strongly influenced by the gas velocity. As an example, a 50%
291 variation in the gas velocity would imply a variation of around 40% in the mass transfer
292 coefficient. This behaviour is in agreement with that found by other authors in the
293 literature (Dorado et al., 2009; Kim and Deshusses, 2008a; Piche et al., 2001). To
294 evaluate the effect of the liquid velocity on the mass transfer coefficient of isopropanol,
295 further experiments were carried out at several liquid velocities. No significant
296 influence of the liquid velocity was observed. This could have occurred since the
297 packing material was completely wet. Kim and Deshusses (2008a) observed that when
298 wetting was almost complete, the effect of liquid velocity was slight or constant. The
299 same behaviour was observed by Piche et al. (2001). No differences between packing
300 materials were found (Fig. 5). Regarding this, Dorado et al. (2009) suggested that when
301 pollutant diffusion is in the gas phase, as is the case with isopropanol, neither the liquid
302 side resistance nor the packing material characteristics affect the global system
303 performance.

304 3.2 Determination of the mass transfer coefficient of oxygen

305 The determination of the mass transfer coefficient of oxygen was extended to the three
306 packing materials shown in Table 1 at several liquid velocities (from 2 to 33 m h^{-1}) and

307 two gas velocities (104 and 312 m h⁻¹). The K_{La} coefficients were obtained using the
308 least squares method in order to minimise the differences between the experimental data
309 and the concentration of oxygen provided by the mathematical model established by Eq.
310 (14) and Eq. (15). The response time of the probe (τ) was determined by means of a step
311 input assay, resulting in a value of 19.4 ± 1.5 s (San-Valero et al., 2013).

312 A typical example of the raw data obtained during one of the experiments and the result
313 of the mathematical procedure described above is shown in Fig. 6. The same
314 mathematical procedure was used for all packing materials, so only one example is
315 shown as a representative of the other packing materials. This corresponds to one test
316 carried out with the packing material Flexiring 25 mm operating at a gas velocity of 104
317 m h⁻¹ and a liquid velocity of 11 m h⁻¹. Similarly to the experiments using isopropanol,
318 the experimental data and the data provided by the mathematical model were evaluated
319 by using the relative error of the concentrations, obtaining an average value less than 2
320 % for all tests done. This confirms that the method was accurate for the determination of
321 the mass transfer coefficient of oxygen.

322 The effect of the gas and liquid velocities on the mass transfer coefficient is shown in
323 Fig. 7 for each packing material. Depending on the packing material and the conditions,
324 K_{La} values were obtained in a range between 20 and 200 h⁻¹ for liquid velocities
325 between 2 and 33 m h⁻¹. These results are consistent with the data obtained by other
326 authors (Kim and Deshusses, 2008a; Piche et al., 2001). As may be seen in this figure,
327 oxygen transfer was enhanced at high liquid velocities. A clear dependence can be
328 observed between the global coefficients and liquid velocities. In addition, these data
329 show that there was not a significant influence of gas velocity on the mass transfer
330 coefficient of oxygen. This is in accordance with the literature (Piche et al., 2001; Kim

331 and Deshusses, 2008a), and is related to the fact that oxygen is a poorly soluble gas in
332 water and the main resistance is located in the liquid phase, in contrast to what occurs
333 with isopropanol.

334 The influence of the packing material was extended to three materials: two random with
335 different specific surface area and one structured. The experimental data from San-
336 Valero et al. (2013) are compiled herein for this purpose. The most important
337 differences in the behaviour of the packing material were observed at liquid velocities
338 above 15 m h^{-1} . This could be due to the fact that turbulence is higher at higher liquid
339 velocities than at lower liquid velocities, thus increasing the interfacial area and
340 facilitating the mass transfer of oxygen between phases, in contrast to the mass transfer
341 of isopropanol where the main resistance was located in the gas phase. For the
342 comparison between packing materials, a velocity of 30 m h^{-1} was chosen since this was
343 the velocity where differences were most evident. In this regard, the structured packing
344 material with a specific surface area of $410 \text{ m}^3 \text{ m}^{-2}$ exhibited the maximum mass
345 transfer coefficient of oxygen with a value around 175 h^{-1} . For the random packing
346 materials, K_{La} values of 130 and 100 h^{-1} were obtained for Refilltech 15 mm and
347 Flexiring 25 mm, with specific surface areas of 348 and $207 \text{ m}^3 \text{ m}^{-1}$, respectively. These
348 data show that a high specific surface area improves the mass transfer of oxygen. The
349 structured packing material exhibited a higher mass transfer coefficient than those
350 obtained with the random packing material with a similar specific surface area. This
351 could be attributed to the effect of different flow paths within the packing materials on
352 the mass transfer of oxygen. Random packing materials could promote channelling
353 more readily than structured packing materials.

354 3.3 Mathematical correlation

355 Mathematical correlations were developed in order to characterise the influence of the
356 gas and liquid velocities on the mass transfer coefficients of isopropanol and oxygen.
357 For the mass transfer of isopropanol, non-significant influences of the packing materials
358 and liquid velocities were observed. Thus, the experimental data can be fitted to a
359 relationship between the mass transfer coefficient and the gas velocity. For the mass
360 transfer of oxygen, two important influences were observed, i.e. the packing material
361 and the liquid velocity. So, it was considered necessary to develop empirical
362 correlations for each of the packing materials. Power law relationships according to Eqs.
363 (18) and (19) between gas or liquid velocity and $K_G a$ or $K_L a$ could be the most suitable
364 way to represent this phenomenon for isopropanol and for oxygen:

$$365 \quad K_G a_{IPA} = c_1 \cdot v_G^{c_2} \quad (18)$$

$$366 \quad K_L a_{OXY} = c_1 \cdot v_L^{c_2} \quad (19)$$

367 where $K_G a$ and $K_L a$ are expressed in h^{-1} , and v_G and v_L in $m h^{-1}$.

368 The parameters obtained for each correlation are shown in Table 2. In order to analyse
369 the accuracy of the empirical correlations proposed herein, the observed and predicted
370 values of the mass transfer coefficient for isopropanol and oxygen are presented in Fig.
371 8. In both cases, the experimental data fit ($r^2 > 0.94$) the predicted data; the greatest
372 observed difference was 20% for the entire data set. These uncertainties are similar to
373 those reported by other authors (Kim and Deshusses, 2008b; Onda et al., 1968).

374 The most general correlations were those proposed by Onda et al. (1968) and Van
375 Krevelen and Hoftijzer (1948) for conventional absorption packing columns. These
376 correlations are described as follows:

377 Onda

$$378 \quad k_G = 5.23 \frac{D_G}{d_p^2 a_p} \left(\frac{\rho_G v_G}{\mu_G a_p} \right)^{0.7} \left(\frac{\mu_G}{\rho_G D_G} \right)^{1/3} \quad (20)$$

$$379 \quad k_L = 0.0051 (a_p d_p)^{-0.4} \left(\frac{\mu_L g}{\rho_L} \right)^{1/3} \left(\frac{\rho_L v_L}{a_e \mu_L} \right)^{2/3} \left(\frac{\mu_L}{\rho_L D_L} \right)^{-0.5} \quad (21)$$

380 Van Krevelen and Hoftijzer

$$381 \quad k_G = 0.2 \frac{D_G}{d_c} \left(\frac{\rho_G v_G}{\mu_G a_p} \right)^{0.8} \left(\frac{\mu_G}{\rho_G D_G} \right)^{1/3} \quad (22)$$

$$382 \quad k_L = 0.015 D_L \left(\frac{\mu_L^2 g}{\rho_L^2} \right)^{-1/3} \left(\frac{\rho_L v_L}{a_e \mu_L} \right)^{2/3} \left(\frac{\mu_L}{\rho_L D_L} \right)^{1/3} \quad (23)$$

383 The assumed supposition that the main resistance to the mass transfer of isopropanol is
384 in the gas phase and for oxygen is in the liquid phase was checked applying the Onda
385 and Van Krevelen and Hoftijzer equations, taking into account both resistances and
386 neglecting one of them for each compound. The error committed neglecting one of the
387 phases was very small (in all cases less than 6%). The hydrodynamics under which
388 these correlations were developed are markedly different than these used in biofiltration,
389 characterised by lower gas and liquid velocities. For this reason, Kim and Deshusses
390 (2008b) developed specific correlations for biotrickling filters for different packing
391 materials.

392 Kim and Deshusses (For Pall ring 1")

$$393 \quad \log(k_G a) = 2.05 + 0.33 \log(v_G) \quad (24)$$

$$394 \quad \log(k_L a) = 0.69 + 0.83 \log(v_L) \quad (25)$$

395 The results obtained herein were compared with these three correlations for the
396 experiments with Flexiring 25 mm. In the case of the equations proposed by Onda and
397 Van Krevelen and Hoftijzer, the wetted area and the effective gas-liquid interface were
398 considered the same as that of the packing material. In the case of Kim and Deshusses,
399 since Pall rings 1" and Flexiring 25 mm have a similar specific surface area, the values
400 of the coefficients proposed in their research were used for comparison purposes.

401 Fig. 9 shows the comparison between the experimental data and correlations for the
402 packing material Flexiring 25 mm. For the mass transfer coefficient of isopropanol (Fig.
403 9a) it is clear that neither correlation found in the literature was capable of simulating
404 the mass transfer coefficients obtained experimentally. The Onda equation
405 overestimated the values of K_Ga by a factor between 2 and 3, while the values provided
406 by the Van Krevelen and Hoftijzer equation underestimated the experimental data. In
407 the case of the equation from Kim and Deshusses, the experimental data were
408 successfully predicted only at low gas velocities.

409 For the mass transfer coefficient of oxygen, the prediction of the Onda correlation fit
410 accurately with the experimental data, and the results predicted by Kim and Deshusses
411 were slightly smaller in comparison. In this case, the results of Van Krevelen and
412 Hoftijzer were clearly quite different from the empirical data.

413 These results show how theoretical and general correlations are not accurate for the
414 prediction of the mass transfer coefficients in biotrickling filters. So, as was proposed
415 by Dorado et al. (2009), using experimental global mass transfer coefficients appears
416 the most suitable way to represent mass transfer. The correlations proposed in this paper
417 are useful for the mathematical modelling of the treatment of vapour emissions of
418 isopropanol with biotrickling filters.

419 4. Conclusions

420 Mass transfer properties for isopropanol and oxygen were determined for several
421 packing materials in the liquid and gas velocity ranges typically used in biotrickling
422 filtration. The Henry's law constant of isopropanol was clearly influenced by the
423 temperature in the ambient range. An empirical correlation based on the Van't Hoff
424 equation was obtained by using experiments with the random packing material Flexiring
425 25 mm. This correlation was validated with the experiments carried out with the
426 structured packing material PAS Winded Media. The influence of the gas and liquid
427 velocities and the packing materials on the mass transfer coefficients of isopropanol and
428 oxygen was determined. The mass transfer coefficient of isopropanol increased almost
429 linearly with gas velocity, while the influences of the liquid velocity and packing
430 material were not significant. The mass transfer coefficient of oxygen was influenced by
431 the packing material and by the liquid velocity. No significant influence of the gas
432 velocity was observed. Based on the data obtained in the present study, power law
433 relationships between the mass transfer coefficient and the gas and liquid velocities
434 were proposed in each case. Three mathematical correlations found in the literature
435 were compared with the empirical data; none of the correlations were capable of
436 reproducing the mass transfer coefficients obtained empirically.

437 The data presented in this paper contain valuable information for modelling the mass
438 transfer coefficients of isopropanol and oxygen. This information is useful for
439 mathematical modelling of physical phenomena that take place during the removal of
440 isopropanol by biotrickling filtration. This paper provides a simple methodology that
441 can be extended to any hydrophilic volatile organic compound.

442 Acknowledgements

443 The research leading to these results has received funding from the People Programme
444 (Marie Curie Actions) of the European Union's Seventh Framework Programme
445 FP7/2007-2013/ under REA grant agreement n° 284949. Financial support from the
446 Ministerio de Ciencia e Innovación (Project CTM2010-15031/TECNO) and Generalitat
447 Valenciana (PROMETEO/2013/053) Spain is also acknowledged. Joaquim Castro
448 Blanch is also acknowledged for his laboratory support. Pau San-Valero acknowledges
449 the Ministerio de Educación, Cultura y Deporte Spain for her FPU contract (AP2010-
450 2191).

451

452 **References**

- 453 Deviny, J. S., Deshusses, M. A., Webster, T. S., 1999. Biofiltration for air pollution
454 control. Boca Raton: CRC-Lewis Publishers.
- 455 Dorado, A. D., Rodriguez, G., Ribera, G., Bonsfills, A., Gabriel, D., Lafuente, J.,
456 Gamisans, X., 2009. Evaluation of mass transfer coefficients in biotrickling filters:
457 experimental determination and comparison to correlations. *Chemical Engineering &*
458 *Technology* 32, 1941-1950.
- 459 Iranpour, R., Cox, H. H. J., Deshusses, M. A., Schroeder, E. D., 2005. Literature review
460 of air pollution control biofilters and biotrickling filters for odor and volatile organic
461 compound removal. *Environmental Progress* 24, 254-267.
- 462 Kim, S., Deshusses, M. A., 2008a. Determination of mass transfer coefficients for
463 packing materials used in biofilters and biotrickling filters for air pollution control. 1.
464 Experimental results. *Chemical Engineering Science* 63, 841-855.
- 465 Kim, S., Deshusses, M. A., 2008b. Determination of mass transfer coefficients for
466 packing materials used in biofilters and biotrickling filters for air pollution control - 2:
467 Development of mass transfer coefficients correlations. *Chemical Engineering Science*
468 63, 856-861.
- 469 Larachi, F., Lévesque, S., Grandjean, B. P. A., 2008. Seamless mass transfer
470 correlations for packed beds bridging random and structured packings. *Industrial &*
471 *Engineering Chemistry Research* 47, 3274-3284.
- 472 Lebrero, R., Estrada, J. M., Muñoz, R., Quijano, G., 2012. Toluene mass transfer
473 characterization in a biotrickling filter. *Biochemical Engineering Journal* 60, 44-49.
- 474 Liss, P. S., Slater, P. G., 1974. Flux of gases across the air-sea interface. *Nature* 247,
475 181-184.
- 476 Onda, K., Takeuchi, H., Okumoto, Y., 1968. Mass transfer coefficients between gas and
477 liquid phases in packed columns. *Journal of Chemical Engineering of Japan* 1(1), 56-62.
- 478 Pérez, J., Montesinos, J. L., Gòdia, F., 2006. Gas-liquid mass transfer in an up-flow
479 cocurrent packed-bed biofilm reactor. *Biochemical Engineering Journal* 31(3), 188-196.
- 480 Piche, S., Grandjean, B. P. A., Iliuta, I., Larachi, F., 2001. Interfacial mass transfer in
481 randomly packed towers: A confident correlation for environmental applications.
482 *Environmental Science and Technology* 35, 4817-4822.
- 483 Sander, R., 2005. Henry's law constants in NIST chemistry WebBook, NIST standard
484 referencedata base number 69, in: Linstrom, P. J., Mallard, W. G. (Eds), National
485 Institute of Standards and Technology. Gaithersburg, MD, USA.

486 San-Valero, P., Penya-Roja, J. M., Sempere, F., Gabaldon, C., 2013. Biotrickling
487 filtration of isopropanol under intermittent loading conditions. *Bioprocess and*
488 *Biosystems Engineering* 36, 975-984.

489 Shareefdeen, Z., Singh, A., 2005. *Biotechnology for odor and air pollution control.*
490 Heidelberg, Germany: Springer.

491 Snider, J. R., Dawson, G. A., 1985. Tropospheric light alcohols, carbonyls, and
492 acetonitrile: Concentrations in the southwestern United States and Henry's Law data.
493 *Journal of Geophysical Research: Atmospheres* 90, 3797-3805.

494 Staudinger, J., Roberts, P. V., 1996. A critical review of Henry's law constants for
495 environmental applications. *Critical Reviews in Environmental Science and Technology*
496 26, 205-297.

497 Staudinger, J., Roberts, P. V., 2001. A critical compilation of Henry's law constant
498 temperature dependence relations for organic compounds in dilute aqueous solutions.
499 *Chemosphere* 44, 561-576.

500 Van Krevelen, D. W., Hoftijzer, P. J., 1948. Kinetics of simultaneous absorption and
501 chemical reaction. *Chemical Engineering Progress* 44, 529-536.

502 Van't Riet, K., 1979. Review of measuring methods and results in nonviscous gas-liquid
503 mass transfer in stirred vessels. *Industrial and Engineering Chemistry Process Design*
504 *and Development* 18(3), 357-364.

505 Weiland, P., Onken, U., 1981. Fluid dynamics and mass transfer in an airlift fermenter
506 with external loop. *German Chemical Engineering* 4, 42-50.

507

508

<i>Nomenclature</i>	
a	Specific interfacial area
a_e	Effective specific interfacial area
a_p	Packing specific surface area
C	Mass concentration
c_1	Empirical coefficient of power law
c_2	Empirical coefficient of power law
D	Diffusion coefficient
d_c	Column inner diameter
d_p	Particle diameter
H	Henry's law constant
K	Overall mass transfer coefficient
k	Individual mass transfer coefficient
Q	Volumetric flow rate
S	Surface of the column
t	Time
V	Volume
V_R	Volume of the reactor
V_T	Volume of the tank
z	Distance from the bottom of the column
Z	Height of the column
ρ	Density
τ	Response time of the probe
μ	Viscosity
<i>Subscripts</i>	
G	Gas
IPA	Isopropanol
L	Liquid
OXY	Oxygen
<i>Sub-subscripts</i>	
A	Inlet to the column of the liquid phase
B	Outlet of the column of the liquid phase
in	Inlet to the column of the gas phase
m	Measured
out	Outlet of the column of the gas phase

510

511

512

513 Table 1 Characteristics of the packing materials

Packing material		Diameter** (mm)	Density** (kg m⁻³)	Bed Porosity** (%)	Specific surface area** (m² m⁻³)
PAS Winded Media*	Structured	----	----	93	410
Flexiring	Random	25	71	92	207***
Refilltech	Random	15	110.7	91	348

514 *Packing material supplied by PAS Solutions BV

515 **Data provided by the suppliers

516 *** Larachi et al. (2008)

517

518 Table 2 Empirical coefficients for the correlations described by Eqs. (18) and (19)

Packing material	$K_G a$ isopropanol (h^{-1})		
	c_1 ($m^{-c_2} h^{(c_2-1)}$)	c_2 (dimensionless)	r^2
PAS Winded Media Flexiring 25 mm	11.59	0.85	0.94
	$K_L a$ oxygen (h^{-1})		
	c_1 ($m^{-c_2} h^{(c_2-1)}$)	c_2 (dimensionless)	r^2
Flexiring 25 mm	10.72	0.65	0.99
PAS Winded Media	9.54	0.84	0.95
Refilltech 15 mm	5.29	0.93	0.99

519

520

521

522

523 Figure Captions

524 Fig. 1 Experimental set-up for the determination of the mass transfer coefficient of
525 isopropanol

526 Fig. 2 Experimental set-up for the determination of the mass transfer coefficient of
527 oxygen

528 Fig. 3 Dependence of the Henry's law constant on temperature

529 Fig. 4 Experimental data and model results for the experiments of the mass transfer
530 coefficient of isopropanol. A) Flexiring 25 mm: 1. $C_{G_{out}}$ 2. C_{L_B} 3. C_{L_A} B) PAS Winded
531 Media: 1. $C_{G_{out}}$ 2. C_{L_B} 3. C_{L_A}

532 Fig. 5 Influence of the superficial gas and liquid velocities on the mass transfer
533 coefficient of isopropanol A) Flexiring 25 mm B) PAS Winded Media

534 Fig. 6 Experimental data and model results for the experiments of the mass transfer
535 coefficients of oxygen

536 Fig. 7 Influence of gas and liquid velocities on the mass transfer coefficients of oxygen.
537 A) Flexiring 25 mm B) PAS Winded Media C) Refilltech 15 mm

538 Fig. 8 Comparison of correlation results and experimental data for mass transfer
539 coefficients: A) Isopropanol B) Oxygen: 1. Flexiring 25 mm 2. PAS Winded Media 3.
540 Refilltech 15 mm. Dotted lines indicate an uncertainty of $\pm 20\%$

541 Fig. 9 Comparison between experimental data and empirical correlations for Flexiring
542 25 mm. A) Isopropanol B) Oxygen

543 Fig. 1 Experimental set-up for the determination of the mass transfer coefficient of
544 isopropanol

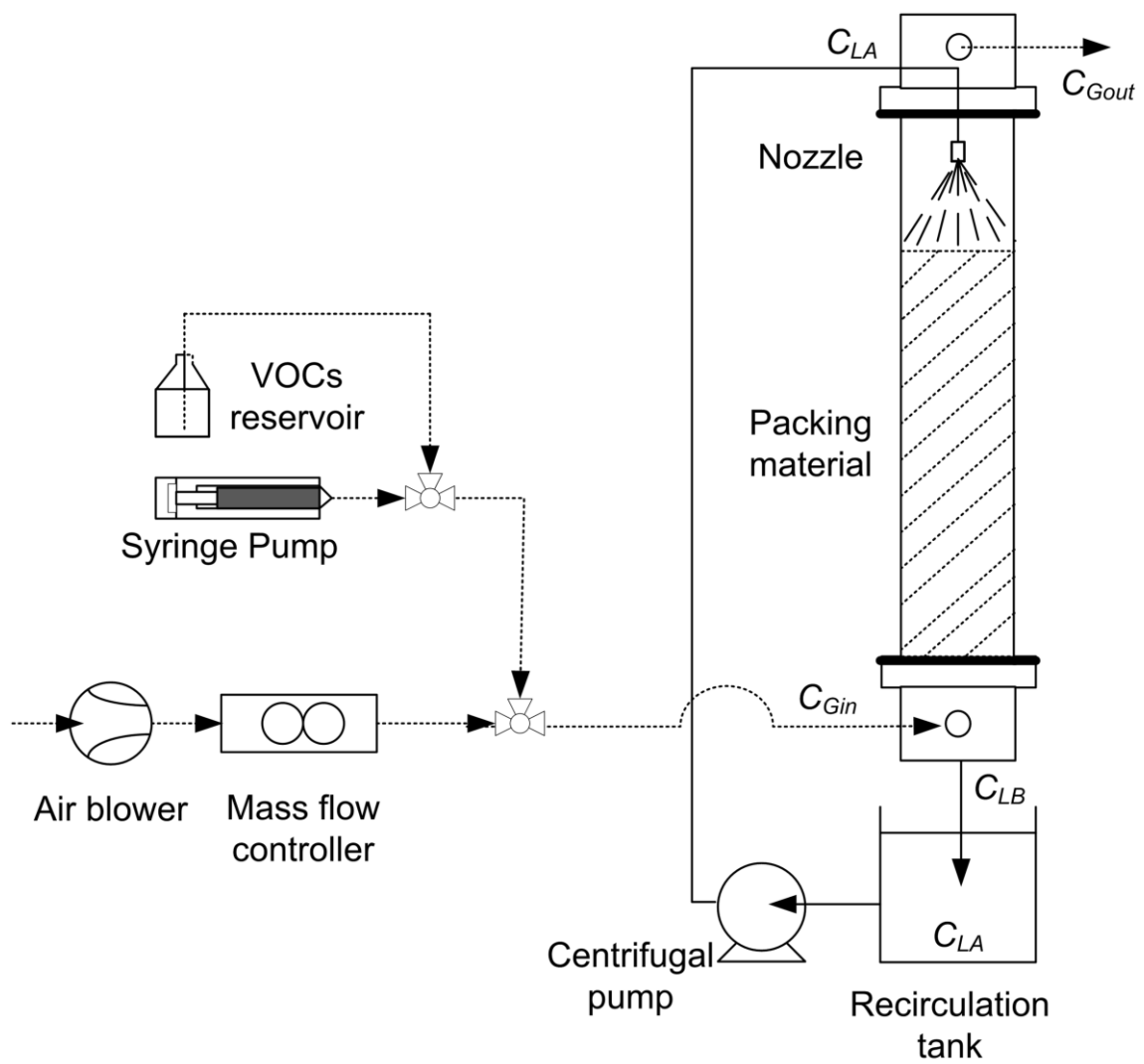

545

546

547 Fig. 2 Experimental set-up for the determination of the mass transfer coefficient of
548 oxygen

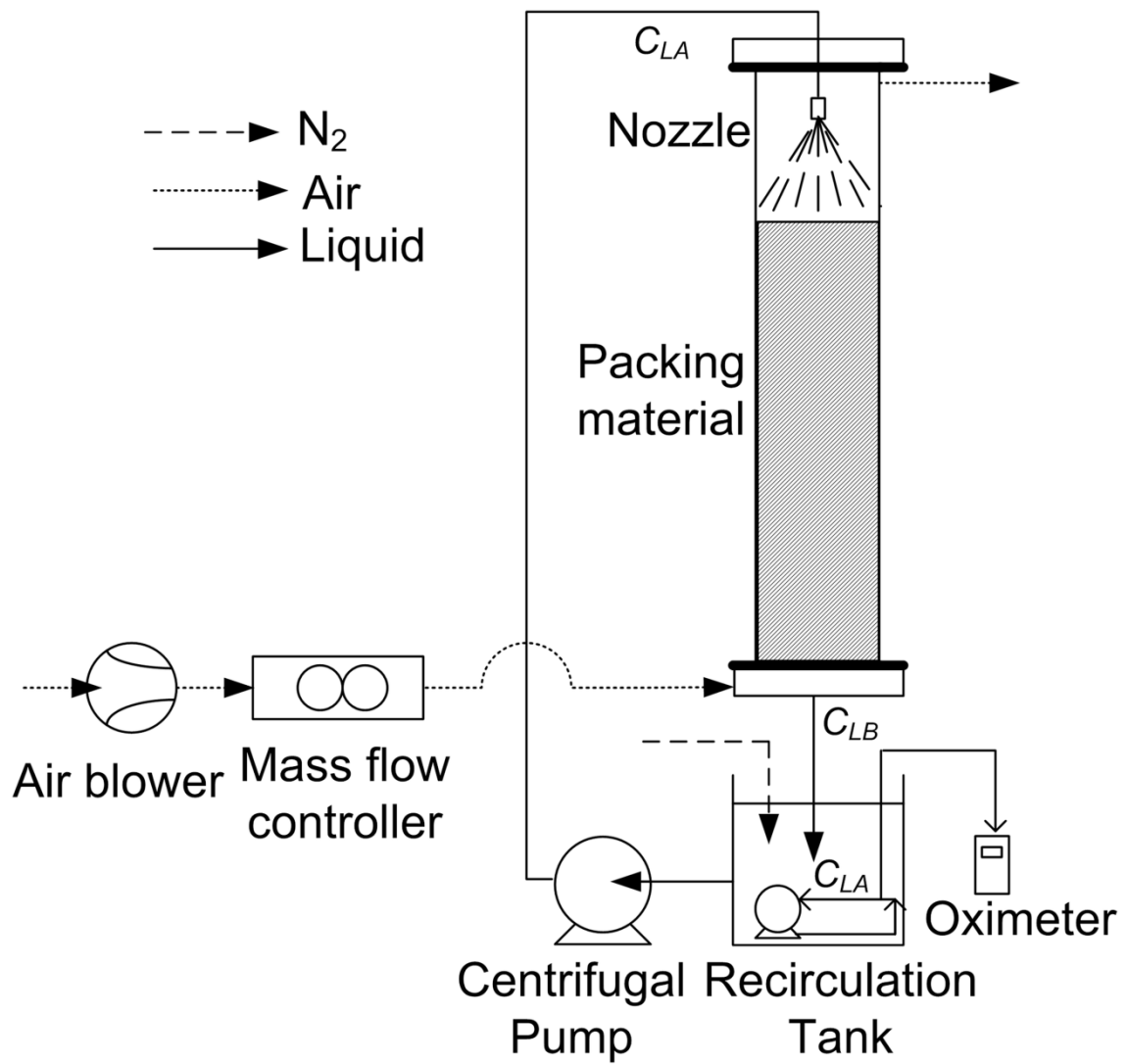

549

550

551 Fig. 3 Dependence of the Henry's law constant on temperature

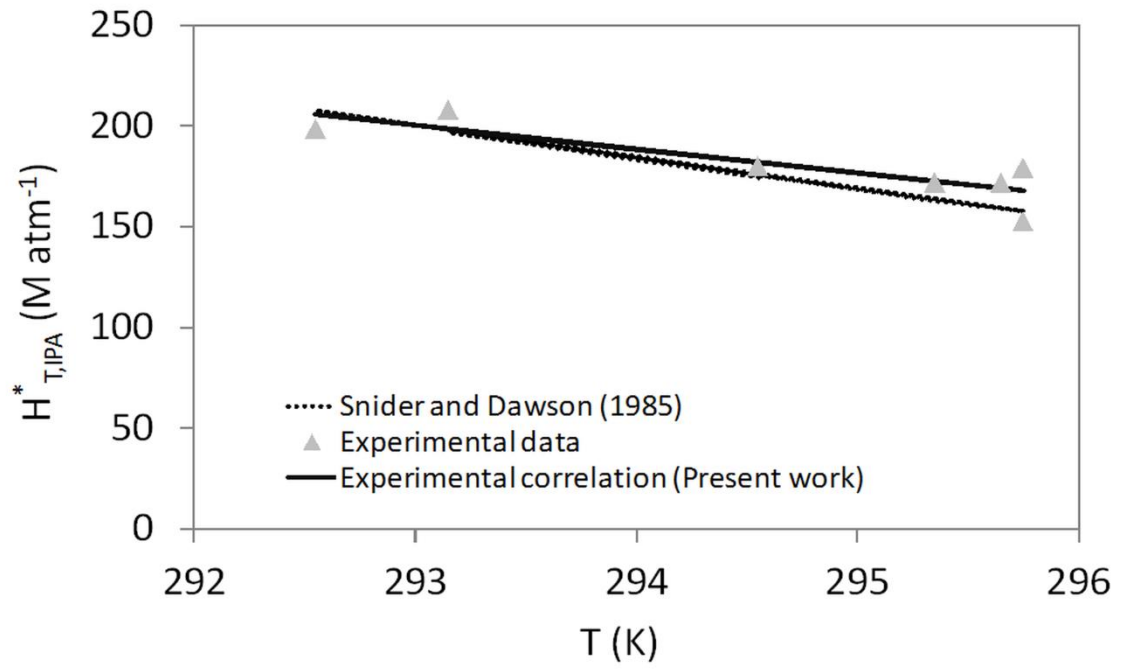

552

553

554 Fig. 4 Experimental data and model results for the experiments of the mass transfer
 555 coefficient of isopropanol. A) Flexiring 25 mm: 1. $C_{G_{out}}$ 2. C_{L_B} 3. C_{L_A} B) PAS Winded
 556 Media: 1. $C_{G_{out}}$ 2. C_{L_B} 3. C_{L_A}

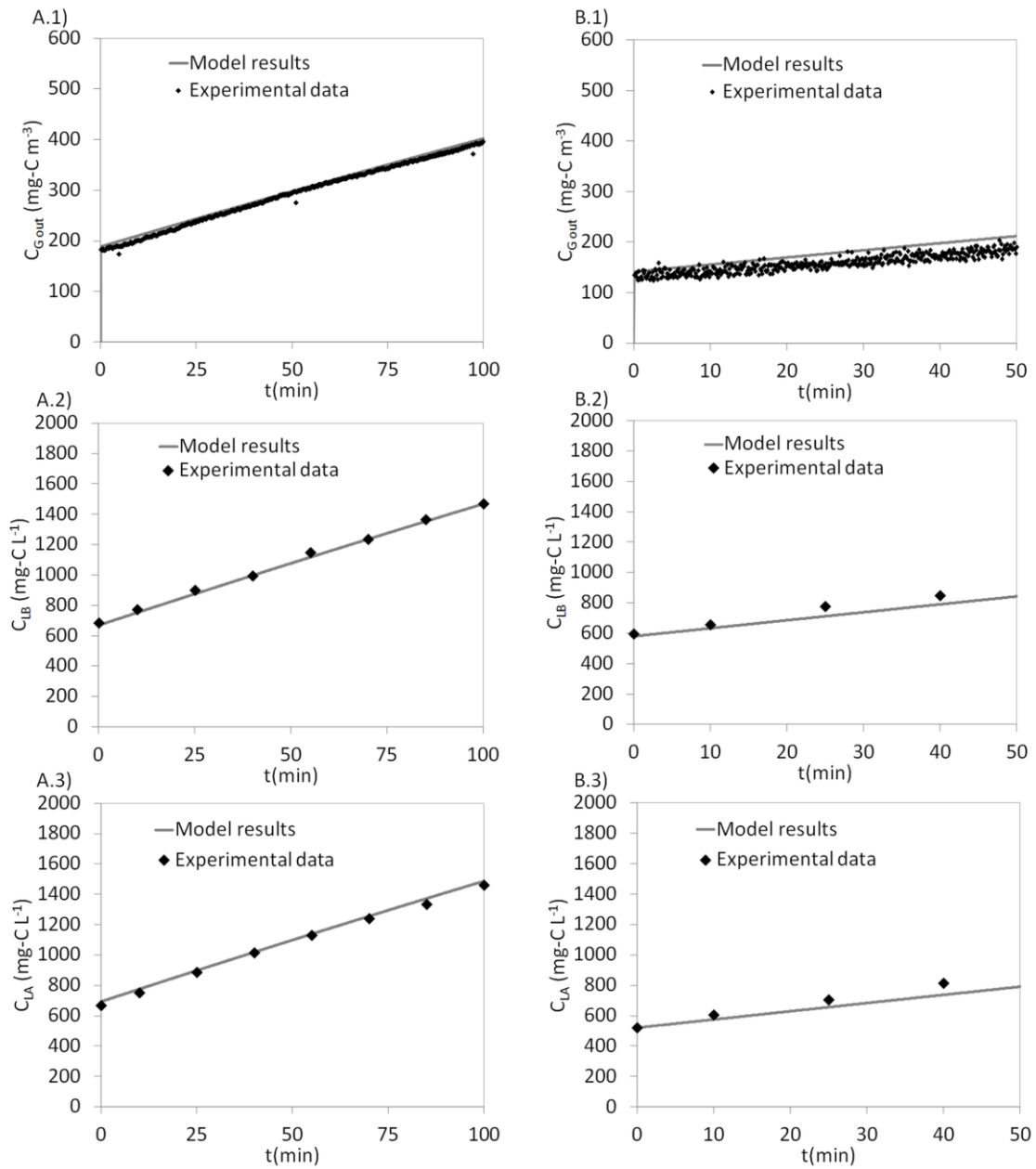

557

558

559 Fig. 5 Influence of the superficial gas and liquid velocities on the mass transfer

560 coefficient of isopropanol A) Flexiring 25 mm B) PAS Winded Media

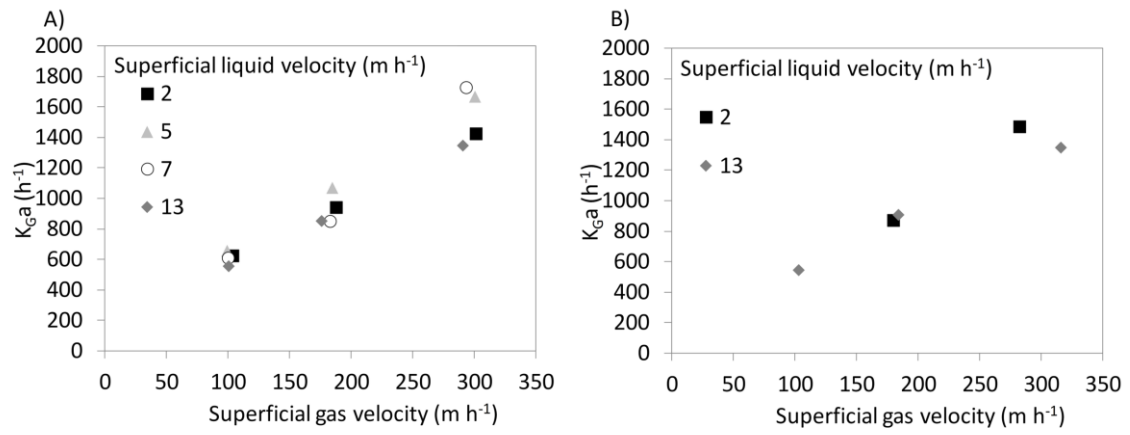

561

562

563 Fig. 6 Experimental data and model results for the experiments of the mass transfer
564 coefficients of oxygen

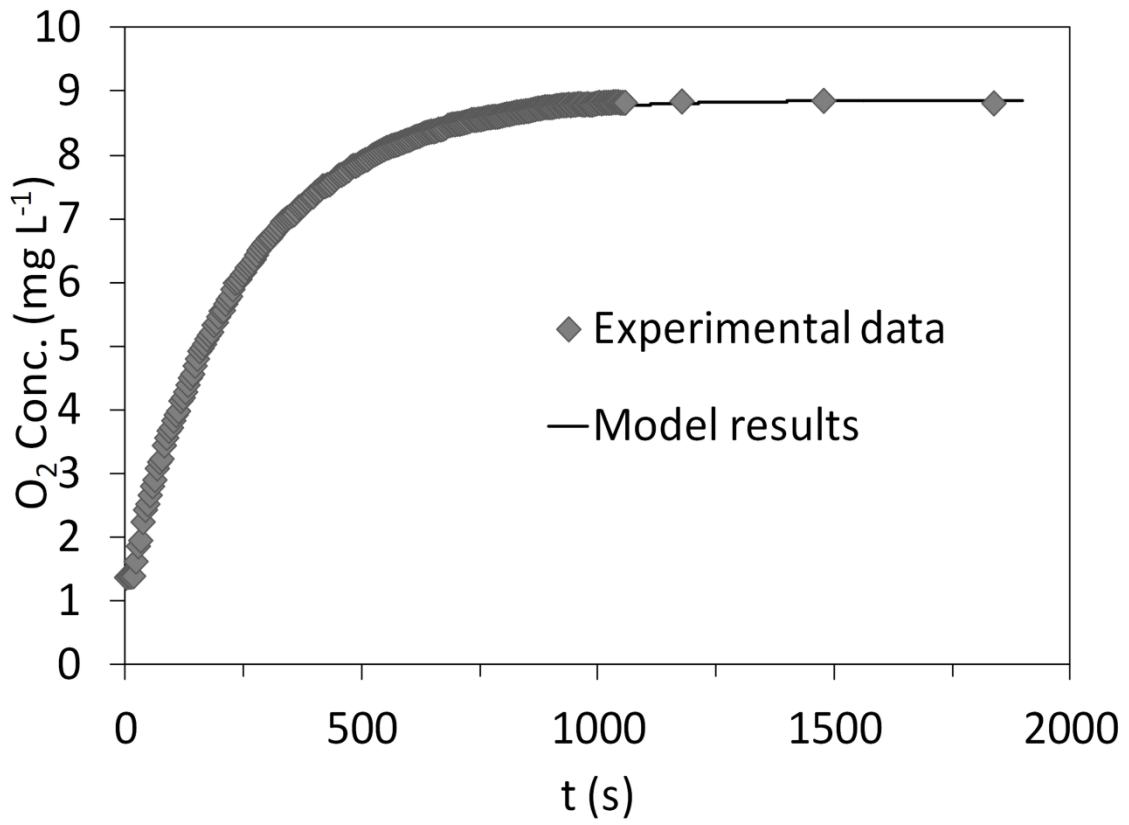

565

566

567 Fig. 7 Influence of gas and liquid velocities on the mass transfer coefficients of oxygen.

568 A) Flexiring 25 mm B) PAS Winded Media C) Refilltech 15 mm

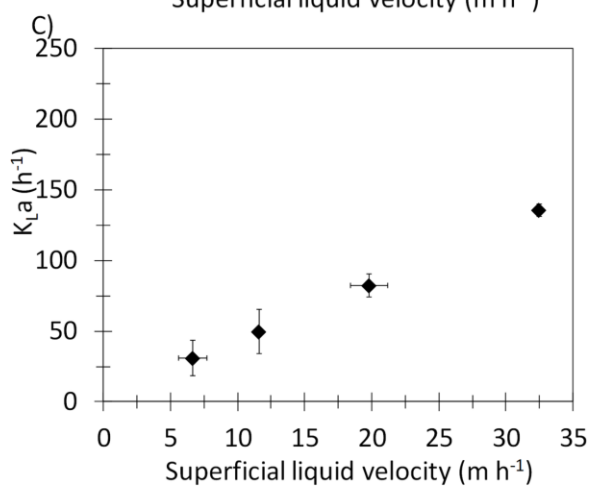
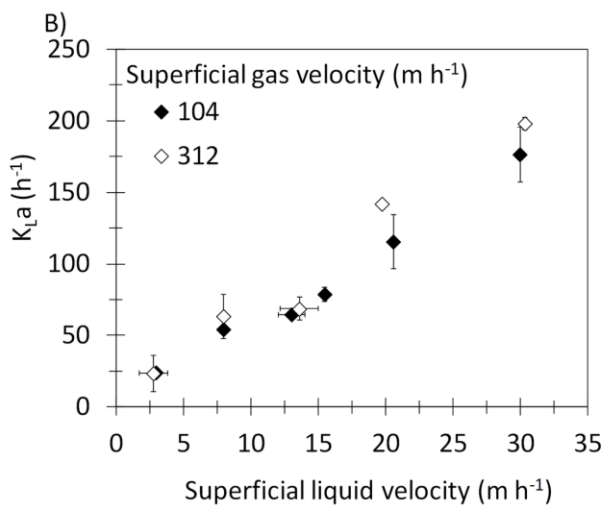
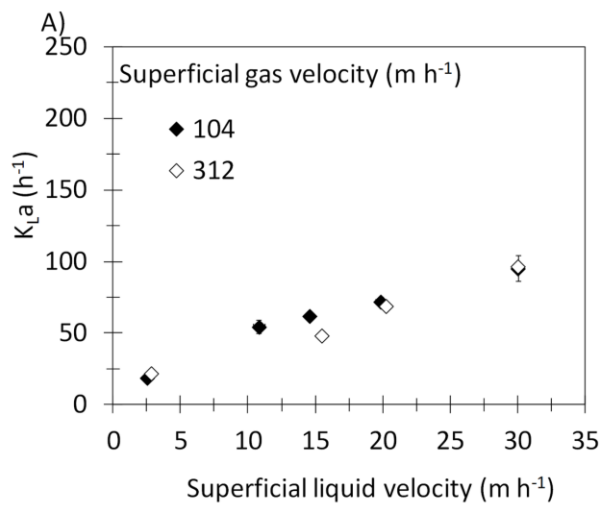

569

570 Fig. 8 Comparison of correlation results and experimental data for mass transfer
 571 coefficients: A) Isopropanol B) Oxygen: 1. Flexiring 25 mm 2. PAS Winded Media 3.
 572 Refilltech 15 mm. Dotted lines indicate an uncertainty of $\pm 20\%$

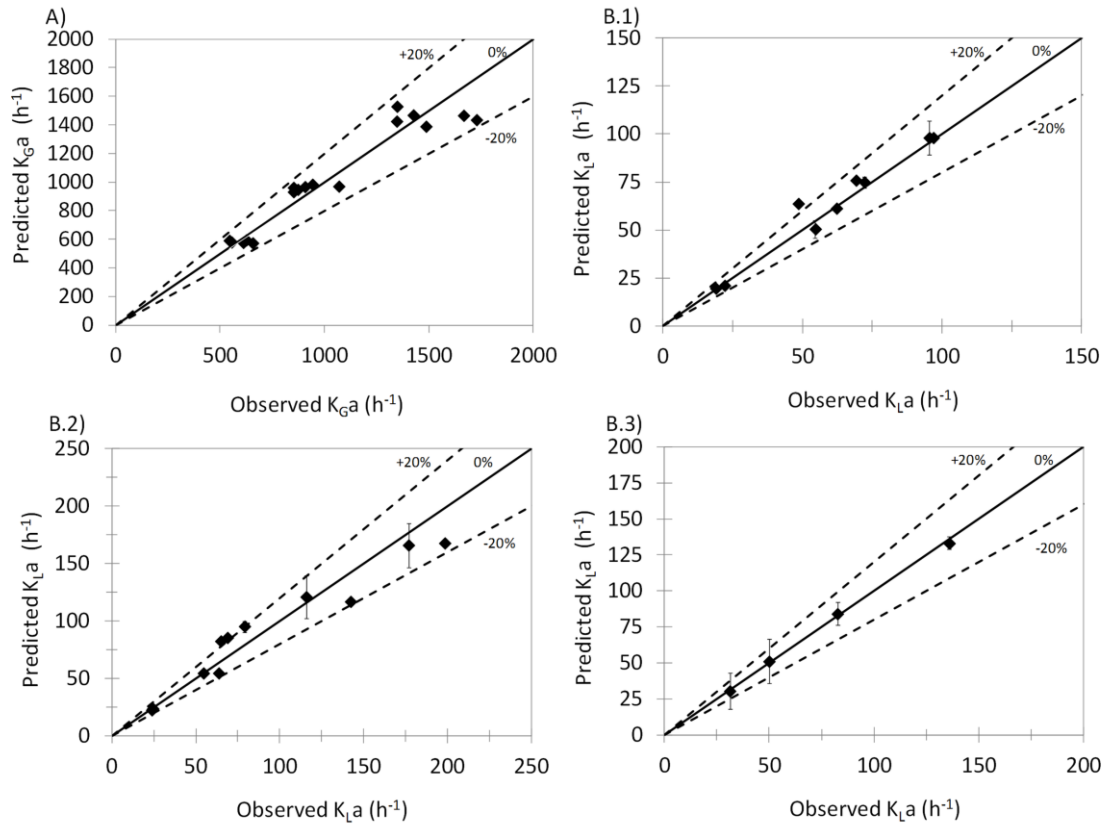

573

574

575 Fig. 9 Comparison between experimental data and empirical correlations for Flexiring

576 25 mm. A) Isopropanol B) Oxygen

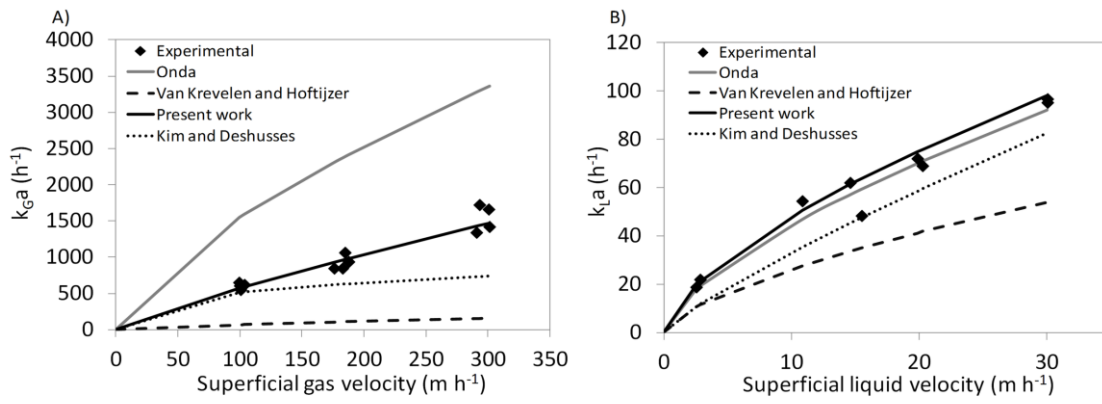

577

578

